

EMINI

OPERATION AND MAINTENANCE

MANUAL

Torque Wrench Power Pump

MODELS: EMINI-115V, EMINI-230V



1025 Conroy Place, Easton PA 18040 * U.S.A.
Phone: +1 610-250-5800 * Fax: +1 610-250-2700
Toll Free: 1-888-TORCUP-1

Email: sales@torcup.com * Website: www.torcup.com



NOTICE

IMPORTANT SAFETY INFORMATION ENCLOSED.
READ THIS MANUAL BEFORE OPERATING PUMP.
IT IS THE RESPONSIBILITY OF THE EMPLOYER TO PLACE THE INFORMATION IN THIS
MANUAL INTO THE HANDS OF THE OPERATOR.
FAILURE TO OBSERVE THE FOLLOWING WARNINGS COULD RESULT IN INJURY.

CONTENTS

Category	Page #	Category	Page #
Manual Index	2	Pressure Torque Setting	10
General Warnings	3	Completing the job	10
Safe and Correct Use	4-6	Periodic Maintenance	10
Warranty Statement	5	Oil Level	6,11
Working Pressure	5	Oil Intake Screen	11
Adding Oil	6	Oil Flushing	11
General Safety	6	Troubleshooting	12
Technical Specifications	7	EMINI Parts Index	13-29
Electrical	8	Pendant	9,23
Connecting Tools	8	Electrical Connection	27
Initial Startup	8	Hydraulic Connection	28
Control Valves	9	4-Port Manifold	29
Power Control Switches	9	Notes	30

TorcUP Inc. is not responsible for customer modification of tools for applications on which TorcUP Inc. was not consulted.

TorcUP has taken every care in preparing this Operational Manual that is intended as a technical guideline only. TorcUP accepts no liability in relation to any use or reliance made of any information in this Operational Manual. All information, illustrations and specifications in this Operational Manual are based on the latest information available at the time of publication. The right is reserved to make changes at any time without notice. Equipment operators and installers shall be responsible for ensuring that a safe working environment and safe systems of work are in place before operating the equipment.

The use of other than genuine TorcUP replacement parts may result in safety hazards, decreased tool performance, and increased maintenance, and may invalidate all warranties. Repairs should be made only by authorized personnel. Consult your nearest TorcUP Authorized Service Center. Refer All Communications to the Nearest TorcUP Office or Distributor.

For Technical Support & Information Contact:
TorcUP Inc.
1025 Conroy Place, Easton, PA 18040 USA
Phone: +1 610-250-5800 Fax: +1 610-250-2700
email: sales@torcup.com

FAILURE TO OBSERVE THE FOLLOWING WARNINGS COULD RESULT IN INJURY

Do NOT exceed Maximum Pressure. See Torque Chart with Tool. Damage May Occur.

Do not use damaged, frayed or deteriorated hydraulic hoses and fittings.



Always wear eye protection when operating or performing maintenance on this tool.



WARNING

Always wear ear protection when operating this tool.



Do not carry the tool by the hose.



Keep body stance balanced and firm. Do not overreach when operating this tool.



The Torque Reaction Arm must be positioned against a positive stop. Do not use the arm as a dead handle. Take all precautions to make certain the operator's hand cannot be pinched between the arm and a solid object.



USING THE TOOL

- Keep hands, loose clothing & long hair away from the reaction arm and working area during operation.
- This tool will exert a strong reaction force. Use proper mechanical support and correct reaction arm positioning to control these forces. Do not position the reaction arm so that it tilts the tool off the axis of the bolt and never use the swivel inlets as a reaction stop.
- Avoid sharp bends and kinks that will cause severe back-up pressure in hoses and lead to premature hose failure.
- Use accessories recommended by TorcUP.
- Use only impact sockets and accessories. Do not use hand (chrome) sockets or accessories.
- Use only sockets and accessories that correctly fit the bolt or nut and function without tilting the tool off the axis of the bolt.
- This tool is not insulated against electric shock.
- This equipment must not be operated or serviced unless the operator read the operating instructions and fully understands the purpose, consequences and procedure of each step.

Depending on the working environment your local health and safety regulations may require you use protective gear (i.e. Ear Protection, Safety Shoes, Hard Hat, Gloves, Coveralls, etc.). In case external forces are exerted on the equipment, non-compliance with these regulations may result in injury. **EAR PROTECTION MUST BE WORN WHEN OPERATING THIS TOOL.**

SAFE AND CORRECT USE

Operation of the Equipment in Accordance with Specified Use

1. Inspect, maintain, operate and install the tool in accordance with all applicable standards and regulations (local, state, country, federal, etc.)
2. Do not remove any labels. Replace any damaged labels immediately.
3. Be sure all hoses and fittings are the correct size and tightly secured.
4. Do not use damaged, frayed or deteriorated hydraulic hoses and fittings. Do not paint hoses.
5. Do not lubricate tools with flammable or volatile liquids such as kerosene, diesel or jet fuel. Use only TorcUP recommended lubricants.
6. Use only proper cleaning solvents to clean parts. Use only cleaning solvents which meet current safety and health standards. Use cleaning solvents in a well ventilated area.
7. Keep work area clean, uncluttered, ventilated and illuminated.

Safety Information When Using The Tool

1. When wearing gloves, always be sure that the gloves will not prevent the throttle mechanism from being released.
2. Always wear eye protection when operating or performing maintenance on this tool.
3. Always wear hearing protection when operating this tool.
4. Always use personal protective equipment appropriate to the tool used and material worked. This may include dust mask or other breathing apparatus, safety glasses, ear plugs, gloves, apron, safety shoes, hard hat and other equipment.
5. Keep others a safe distance from your work area, or ensure they use appropriate personal protective equipment.
6. Be aware of buried, hidden or other hazards in your work environment. Do not contact or damage cords, conduits, pipes, or hoses that may contain electrical wires, explosive gases or harmful liquids.
7. Keep hands, loose clothing, long hair and jewelry away from working end of tool.
8. Power tools can vibrate in use. Vibration, repetitive motions or uncomfortable positions may be harmful to your hands and arms. Stop using any tool if discomfort, tingling feeling or pain occurs. Seek medical advice before resuming.
9. Keep body stand balanced and firm. Do not overreach when operating this tool. Anticipate and be alert for sudden changes in motion, reaction torques, or forces during start up and operation.
10. **DO NOT USE THIS TOOL WHEN TIRED, UNDER THE INFLUENCE OF MEDICATION, DRUGS OR ALCOHOL.**
11. Never use a damaged or malfunctioning tool or accessory.
12. Do not modify the tools, safety devices or accessories.
13. Do not use this tool for purposes other than those recommended
14. Never exceed rated pressure of tool.

SAFE AND CORRECT USE

IMPORTANT - READ CAREFULLY

This manual contains important information for the correct installation, operation and maintenance of this equipment. All persons involved in the installation, operation and maintenance of this equipment must be thoroughly familiar with the contents of this manual. To safeguard against the possibility of personal injury or property damage, follow the recommendations and instructions of this manual. Keep this manual for reference.

WARRANTY STATEMENT

TorcUP products are warranted to be free of defects in materials and workmanship under normal use for as long as the original purchaser owns them, subject to the guidelines and limitations listed. This warranty does not cover: normal wear & tear, cosmetic items, abuse, overloading, alterations, improper fluid, or use in a manner for which they are not intended. If the customer believes a product is defective, the product must be delivered, or shipped freight prepaid, to the nearest TorcUP Authorized Service Center for evaluation and repair. This pump offers 13 month warranty.

RECEIVING INSTRUCTIONS

Important! Make sure to inspect all of the components for shipping damage. If damage is found, notify carrier at once. Shipping damage will not be covered by warranty. The carrier is responsible for all loss associated with shipping damage.

SAFETY

Make sure to read the instructions, warnings and precautions carefully. Follow any recommended safety precautions to avoid personal injury or damage to the unit. TorcUP cannot be responsible for any damage or injury from unsafe use, lack of maintenance or incorrect operation. In the event any questions or concerns arise, contact TorcUP or a local representative for clarification.

The pump's maximum working pressure is 10,000 PSI(700kg/cm²). Make sure that all hydraulic equipment such as rams, hoses, etc. used with this pump are rated at 10,000 PSI (700kg/cm²) operating pressure.

If you have never been trained on high-pressure hydraulic safety, consult your representative for a free TorcUP Hydraulic Safety Course.

Failure to comply with the following cautions and warnings could cause equipment damage, property damage or personal injury.

DANGER is only used when your action or lack of action may cause serious injury or even death.

WARNING indicates a potential danger that requires correct procedures or practices to avoid personal injury.

CAUTION is used to indicate correct operating or maintenance procedures and practices to prevent damage to, or destruction of equipment, or other property.

SAFE AND CORRECT USE

WARNING: Wear proper personal protective gear when operating hydraulic equipment.

DANGER: To avoid personal injury, keep hands and feet away from work-piece during operation.

WARNING: Do not exceed equipment ratings. Overloading causes equipment failure and possible personal injury. The pump tools are designed for a maximum pressure of 10,000 PSI (700kg/cm²). Do not connect a jack or cylinder to a pump. Never set the relief valve to a higher pressure than the maximum rated pressure of the pump. Higher settings may result in equipment damage and/or personal injury.

WARNING: The system operating pressure must not exceed the pressure rating of the lowest rated component in the system. Install pressure gauges in the system to monitor operating pressure.

CAUTION: Avoid damaging hydraulic hose. Avoid sharp bends and kinks when routing hydraulic hoses. Using a bent or kinked hose will cause severe back-pressure. Sharp bends and kinks will internally damage the hose, leading to premature hose failure. Do not drop heavy objects on hose. A sharp impact may cause internal damage to hose wire strands. Applying pressure to a damaged hose may cause it to rupture.

IMPORTANT: Do not lift hydraulic equipment by the hose or swivel couplers. Use the carrying handle or other means of safe transport.

CAUTION: Keep hydraulic equipment away from flames and heat. Excessive heat will soften seals, resulting in fluid leaks. Heat also weakens hose materials. For optimum performance do not expose equipment to temperatures of 65° C (170° F) or higher. Protect hoses and cylinders from weld spatter.

TECHNICAL SPECIFICATIONS

WORKING PRESSURE

The pump's maximum working pressure is 10,000 PSI (700kg/cm²). Make sure that all hydraulic equipment such as tools, hoses, etc. used with this pump are rated at 10,000 PSI (700kg/cm²) operating pressure.

ADDING OIL

Remove oil filler cap and add TorcUP hydraulic oil into reservoir. Oil level should not exceed 1" from the reservoir cover. Oil should be ISO 32 or 46 weight.

*As a "rule of thumb" oil should be filled about an inch below the top of the reservoir when the unit is powered down and all connected tools or cylinders are retracted.

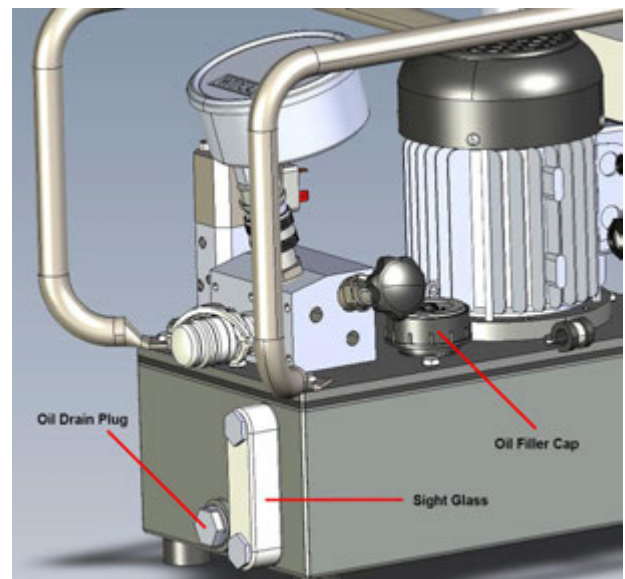

TECHNICAL SPECIFICATIONS

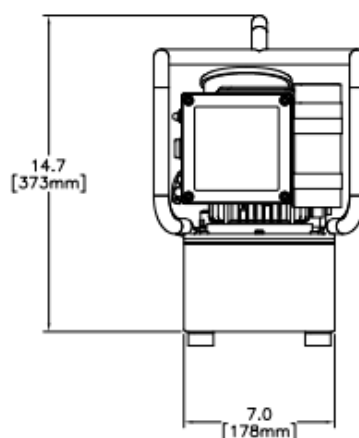
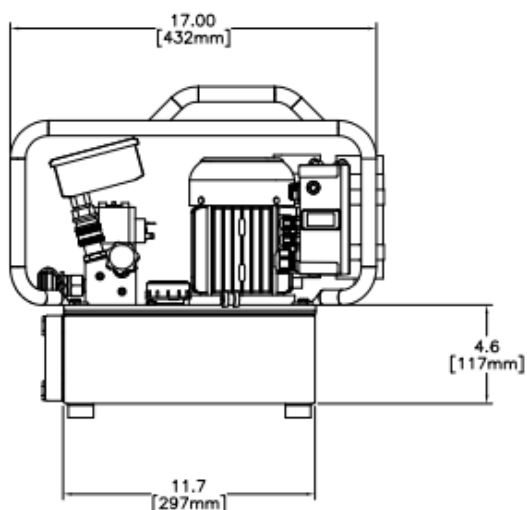
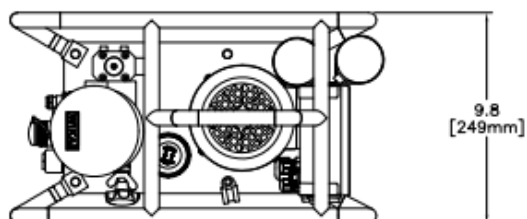

DIMENSIONS	Inch	mm
LENGTH	17	432
WIDTH	9.8	249
HEIGHT	14.7	373

RESERVOIR SIZE	Inch	mm
LENGTH	11.7	297
WIDTH	7.0	178
HEIGHT	4.6	117

OIL CAPACITY	Gallon	Liter
	1.4	5.3

WEIGHT APPROX. W/O OIL	lbs	kg
	39lbs	17.7kg

Electrical / Motor Specs (2 - Stage)	SERVICE SUPPLY		
	115V: 1Ph 100-115 / 50+60Hz		
	230V: 1Ph 200-230 / 50+60Hz		
	MOTOR DRAW		
	115V: 0.6 kW / 0.8 HP 8 Ampere 230V : 0.6 kW / 0.8 HP 5 Ampere		
	Max. Current draw	115V	230V
	100bar (idle)	5.5A	3.7A
	500bar	6.7A	4.2A
	700bar	7.6A	4.8A

MAX OIL FLOW	50Hz		60Hz	
Stage 1 (1000psi / 70bar)	260 cu.in/min	4.2 l/min.	310cu.in/min	5.0 l/min.
Stage 2 10,000psi / 700bar)	26 cu.in/min	0.4 l/min.	31 cu.in/min	0.5 l/min.

TECHNICAL SPECIFICATIONS

WARNING

Loose or improperly threaded fittings can be potentially dangerous if pressurized; however, severe over tightening can cause premature thread failure. Fittings need to be tightened secure and leak free. Never hold or stand directly in line with any hydraulic connections while pressurizing. Never grab, touch or in any way come in contact with a hydraulic pressure leak. Escaping oil can penetrate the skin and a serious injury can result.

CAUTION: Do not subject the hose to potential hazards such as sharp surfaces, extreme heat or heavy impact. Do not allow the hose to kink or twist. Inspect each hose for wear before it is used.

ELECTRICAL

Check for proper electrical supply before connecting. Be sure the electrical connection is grounded. Check that your power supply agrees with the motor nameplate and/or TorcUP model decal.

NOTE: MOTOR MAY SPARK. DO NOT OPERATE IN AN EXPLOSIVE ATMOSPHERE OR IN THE PRESENCE OF CONDUCTIVE LIQUIDS.

1. Do not use a power or extension cord that is damaged or has exposed wires.
2. All single phase motors come equipped with a three prong grounding type plug to fit the proper grounded type electrical outlet. Do not use a two prong ungrounded extension cord as the pump's motor must be grounded.

CONNECTING HYDRAULIC TOOLS

Use only tools, hoses and accessories rated at 10,000 PSI (700kg/cm²). When making connections with quick disconnect couplings, make sure the couplings are fully engaged. Threaded connections such as fittings, gauges, etc. must be securely tightened and leak free. Use 1.5 wraps of Teflon tape (or suitable thread sealant) on all threads, leaving the first complete thread free of tape to ensure no foreign matter enters the hydraulic circuit.

STARTING THE PUMP FOR THE FIRST TIME

1. Check for any leaks, repair as needed.
2. When first plugged in the solenoid makes 4 "clicks" relieving any pressure still in the system. When the button to turn off the pump is pressed it goes through the same sequence for the same reason. It is then safe to remove tool and hoses.
3. Shift pendant to the advance position to advance tool and release to retract tool. Look for movement in tool, check for any leaks, repair as needed.

CAUTION: Never operate the pump without tool movement for more than 1 minute. Leaving the valve in the advance or retract position without the tool's piston rod moving will overheat the oil.

CAUTION: Never disconnect or connect any hydraulic hoses or fittings without first unloading the tool, then unplug the electrical cord of the pump. Open manual relief valve to assure that the system has been depressurized.

TECHNICAL SPECIFICATIONS

CONTROL VALVES

2-Position – 4 Way Solenoid Valve for Hydraulic Torque Wrenches.

To Advance - depress the Advance Switch.
To Retract - release advance switch to Retract Tool.

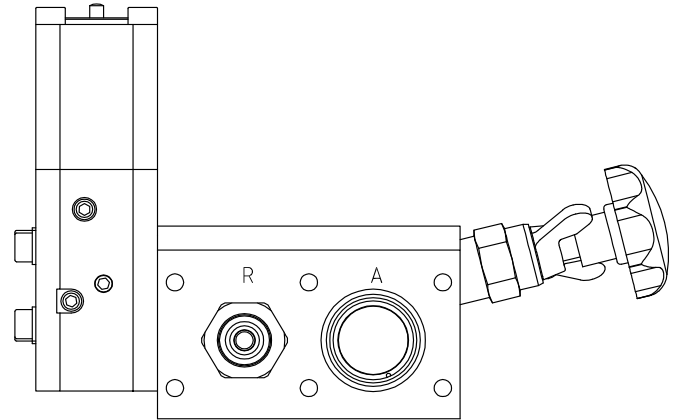

INSTALL HYDRAULIC CONNECTIONS

Use only tools, hoses and accessories rated at 10,000 PSI (700kg/cm²). Use 1.5 wraps of Teflon tape (or suitable thread sealant) on all threads, leaving the first complete thread free of tape to ensure no foreign matter enters the hydraulic circuit.

When making connections with quick disconnect couplings, make sure the couplings are fully engaged. Threaded connections such as fittings, gauges, etc. must be securely tightened and leak free.

POWER CONTROL SWITCHES

Remote pendant.
Configured with motor control pendant:

Press "ADV" to
turn pump ON

Press and release
"ADV" to cycle

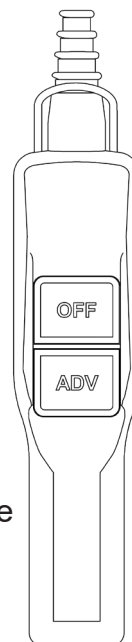

Press "OFF" to
turn pump OFF

OPERATION PROCEDURES

PRESSURE TORQUE SETTING

WARNING

Make these adjustments BEFORE putting torque wrench on nut or bolt head. The pump pressure setting may be above the pressure needed to provide the required torque for your application. Exceeding required torque will cause equipment damage and may lead to serious personal injury.

1. See torque wrench instructions for amount of pressure required to produce desired torque.
2. Loosen lock nut and back out relief valve to prevent unintended pressure builds up.
3. Turn pump on. Press and hold the "ADV" switch, and read pressure gauge.
4. While holding the switch, turn relief valve in (clockwise) to increase pressure or out (counter-clockwise) to decrease maximum pressure. Repeat until correct pressure is obtained.
5. Tighten lock nut on the relief valve to maintain setting.
6. Run pump several times to test this setting before setting tool on the nut.

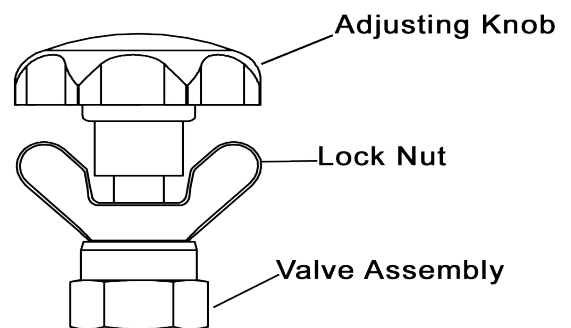

AFTER COMPLETING THE JOB

Before disconnecting hoses, fittings, etc., first be sure the tool is unloaded and retracted, then unplug the power cord.

PERIODIC MAINTENANCE

Completely change the hydraulic oil and clean the intake screen and magnet (located in the reservoir) twice a year. If equipped, change the external oil filter twice a year (Use TorcUP oil only, Model # AO1, 1 gallon). Change the oil more frequently when used in extremely dusty areas or when the oil has been overheated. Using oil other than TorcUP recommended may void the pump's warranty.

The following conditions require more frequent oil changes.

- Rigorous duty, where oil temperature may reach 150° F.
- High humidity environment and extreme changes in temperature that can result in condensation inside the reservoir.
- Dirty or dusty environments that may contaminate the oil.
- Frequent connection and disconnection of hydraulic hoses and components.

WARNING

The electrical power cord must be disconnected from electrical outlets before performing maintenance or repair procedures.

OPERATION PROCEDURES

MAINTAIN OIL LEVEL

Check hydraulic oil level every 30 hours of operation (sight gauge should be completely covered in oil when all tools are retracted. Add TorcUP oil (Model # AO1 – 1 gallon) when necessary. Oil level should be no more than 1" from top of reservoir plate – with cylinders retracted and motor off.

CLEAN OIL INTAKE SCREEN ONCE A YEAR

Loosen and remove reservoir plate bolts. Lift pump unit off the reservoir, being careful not to damage the gasket.

Remove suction filter by rotating counter clockwise. Clean with nonflammable solvent, blow dry clean. Reinstall in reverse order and torque bolts to 75 inch pounds. Keep the motor and pump as clean as possible.

FLUSH THE PUMP

If you suspect your pump has been contaminated or discover sludge or other deposits on internal components, you should thoroughly flush the pump. Remove the old oil from the reservoir, then thoroughly clean the reservoir and refill with a clean, nonflammable flushing oil. Reassemble the pump and motor to the reservoir.

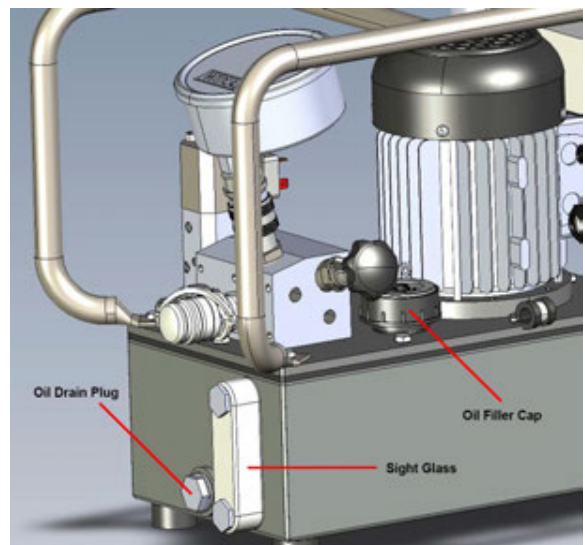

Run the pump in no load condition for 1 or 2 minutes maximum. Unplug the pump and remove the motor and pump assembly again. Now drain the flushing oil and re-clean the inside of the reservoir. (Make sure flushing fluid is also drained from pump assembly). Reassemble the pump and refill the reservoir with TorcUP hydraulic oil and reassemble the pump.

TROUBLESHOOTING

PROBLEM

CAUSE-SOLUTION

- | | |
|----------------------------------|--|
| Sporadic Tool Action: | <ul style="list-style-type: none">• Air in the hydraulic system. Bleed the hydraulic circuit.• Check reservoir oil level. |
| Motor Will Not Start: | <ul style="list-style-type: none">• Be sure power cord is not damaged.• Check for tripped circuit breaker; be sure breaker is of adequate size.• Have motor checked for proper operation.• Have qualified electrician inspect for loose or faulty wiring or switch. |
| Noisy Operation: | <ul style="list-style-type: none">• Air in system.• Be sure the oil reservoir is filled to normal level.• Check all points where air might leak into system.• Clogged or blocked intake screen. |
| Pump Oil is Over Heating: | <ul style="list-style-type: none">• Inspect for high pressure leakage at the pump (leaking at plug or relief valve).• Oil level is low. Fill reservoir to normal level, or retrofit the pump with larger reservoir or heat exchanger. |
| Pump Runs But Will Not Pump Oil: | <ul style="list-style-type: none">• Pump is not primed. Run pump a few minutes tipping from side to side.• Inspect to make sure that external adjustable relief valve is set properly.• Defective control valve, take to nearest TorcUP Authorized Service Center for repair.• Incorrect motor rotation, take to nearest TorcUP Authorized Service Center for repair.• Check to make sure the intake screen is not clogged. Clean if needed.• Check oil reservoir is low. Fill as needed.• Oil viscosity is too high. Replace with TorcUP oil. |

PARTS INDEX

EMINI-115V / 230V

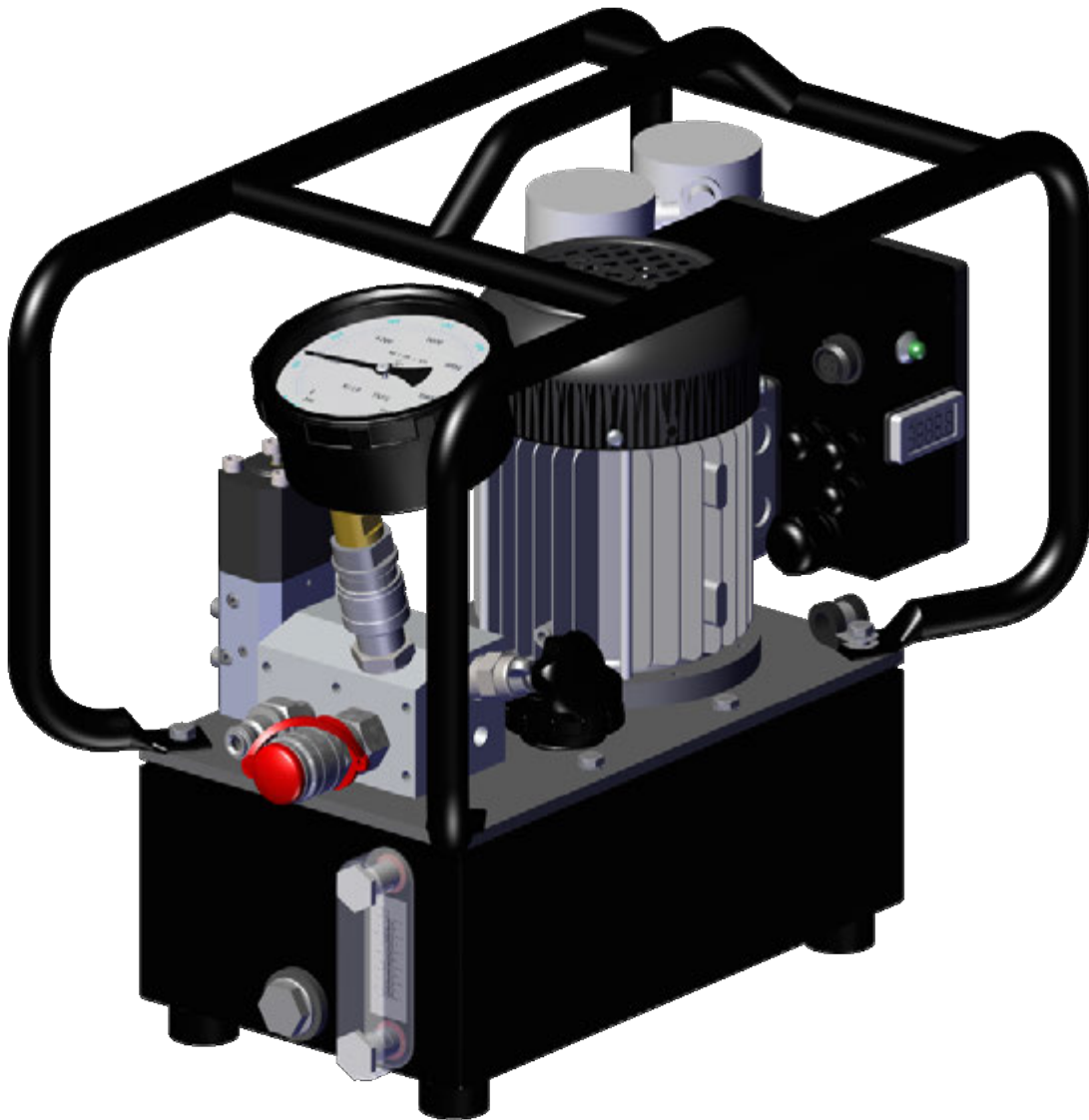

HYDRAULIC PUMP

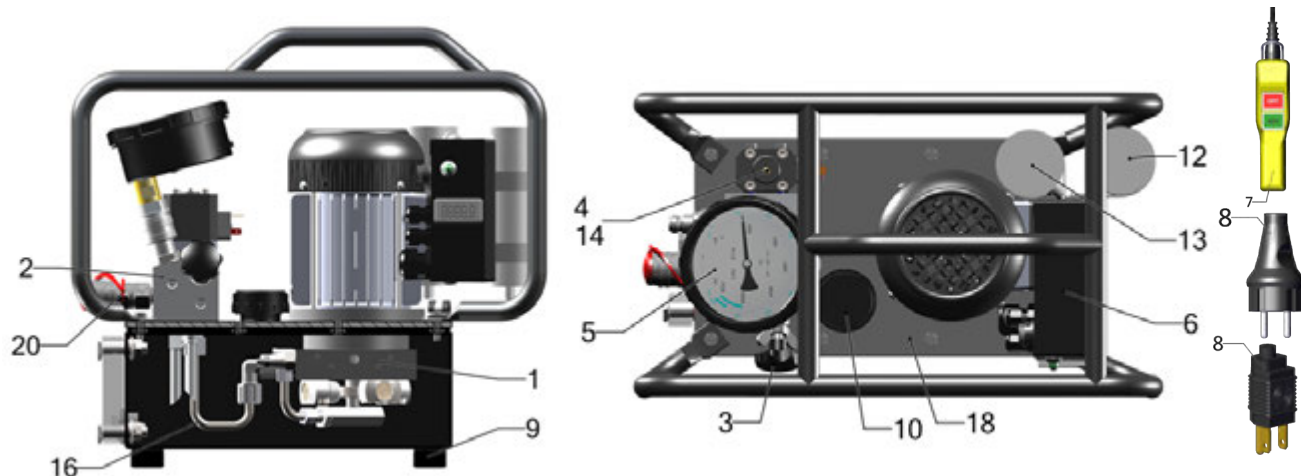

Item	Quantity	Name	Type	Part. No.
1	1	Motor-pump-unit		
*1.10	1	Subassembly Motor-Unit		
*1.20	1	Subassembly Shaft		
*1.30	1	Subassembly Motor Flange		
*1.40	1	Subassembly Pump		
*2	1	Valve Block compl. but without manometer, solenoid-valve and torque valve		
*3	1	Torque Valve		
*4	1	Solenoid Valve	115V	M-111094
*4	1	Solenoid Valve	230V	M-111095
*5	1	Pressure Gauge		PBG-2-N. Flange
*6	1	Electric Control		
*7	1	Remote Control compl.		
8	1	Power Cord	115V / 3,5m	M-102191
8	1	Power Cord	230V / 3,5m	M-102186
*9	1	Oil Reservoir compl.		
10	1	Air Escape Valve	TMDV/12-DS/1	M-103732
*11	1	Oil Cooler compl.		

Ref. item 12 & 13 Attention: different version for 115V/230V

12	1	Operating Capacitor (115V pump)	60μF, 280V, Ø55, UL, IP65	M-111069
12	1	Operating Capacitor (230V pump)	20μF, 450V, Ø45	M-104533
13	1	Starting Capacitor (115V pump)	100μF, 330V, Ø55, UL, IP65	M-111069
13	1	Starting Capacitor (230V pump)	20μF, 450V, Ø45	M-104533
14	1	Solenoid Cable	43650B-180°-GLR, 450, 120-AE	M-109215
*15	1	Carrying Handle		
16	1	Pipework (Valve Block)		M-111037
17	1	Cover		M-111798
*20	1	Male Nipple		HC-M-100
*20	1	Female Coupler		HC-F-400

SUBASSEMBLY MOTOR UNIT

ITEM 1.1

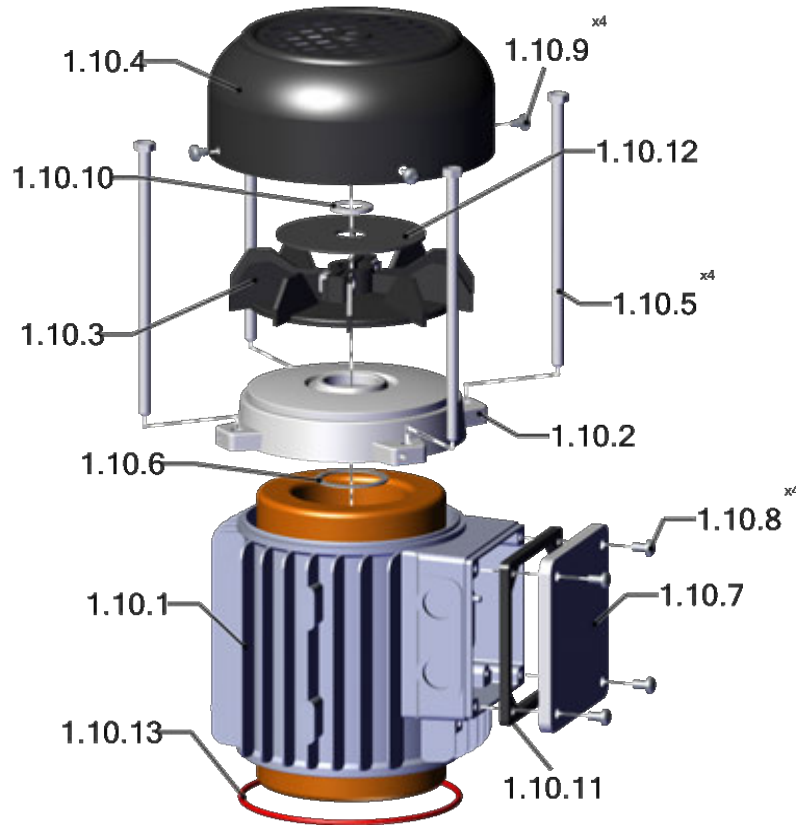

Ref. item 1.10.1 Attention: different version for 115V/230V

Item	Quantity	Name	Type	Part. No.
1.10.1	1	motor-housing (stator)	M63-90/110V	M-110961
1.10.1	1	motor-housing (stator)	M63-90/220V	M-111098
1.10.2	1	end plate	M 63	M-104672
1.10.3	1	fan wheel	M 63	M-104721
1.10.4	1	fan housing	M 63	M-104733
1.10.5	4	hexagon screw	M5x125	M-108679
1.10.6	1	bearing press proof washer	M 63	M-104676
1.10.7	1	cover	Bg.63/71	M-103788
1.10.8	4	self tapping screw 3,5x13 galv.	3.5x13 galv. ISO 7049C	M-106985
1.10.9	4	self tapping screw 3,9x6,5 galv.	3.5x13 galv. ISO 7049C	M-106984
1.10.10	1	spring washer	Ø11	M-104016
1.10.11	1	sealing for clamp box		M-103786
1.10.12	1	flat sealing fan wheel M71	M71	M-101927
1.10.13	1	o-ring 108x3-70 VMQ-red	93x1-70 VMQ-red	M-106753

SUBASSEMBLY MOTOR UNIT

ITEM 1.2

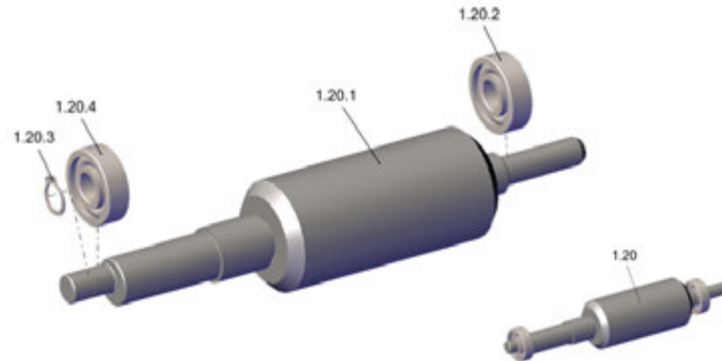

Item	Quantity	Name	Type	Part. No.
1.2	1	Shaft, Complete		M-111616
1.20.1	1	Shaft	M71-110-ZP	M-101152
1.20.2	1	Ball Bearing	6201-C-2HRS	M-105868
1.20.3	1	Retaining Ring	12x1 DIN471	M-106878
1.20.4	1	Ball Bearing	6201.ZZCM	M-0105860

SUBASSEMBLY MOTOR FLANGE

ITEM 1.2

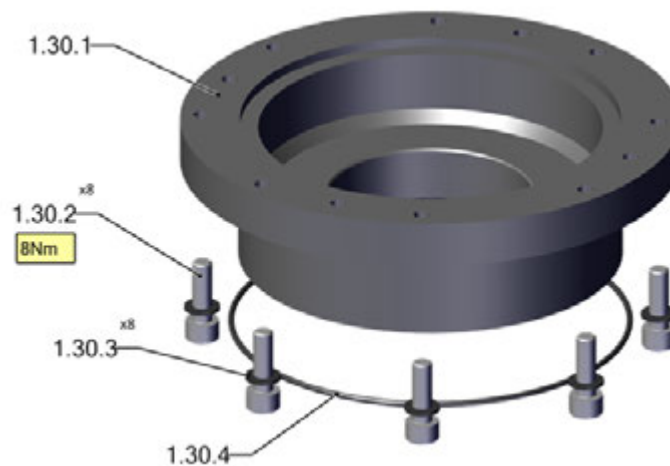

Item	Quantity	Name	Type	Part. No.
1.30.1	1	Motor Flange		M-101996
1.30.2	8	Cylinder Head Screw	M5x18-8.8 galv.	M-108685
1.30.3	8	Sealing Ring	5x9x1 WE DIN 7603	M-106843
1.30.4	1	O-Ring	97x1,5-70NBR	M-106747

SUBASSEMBLY PUMP

ITEM 1.4

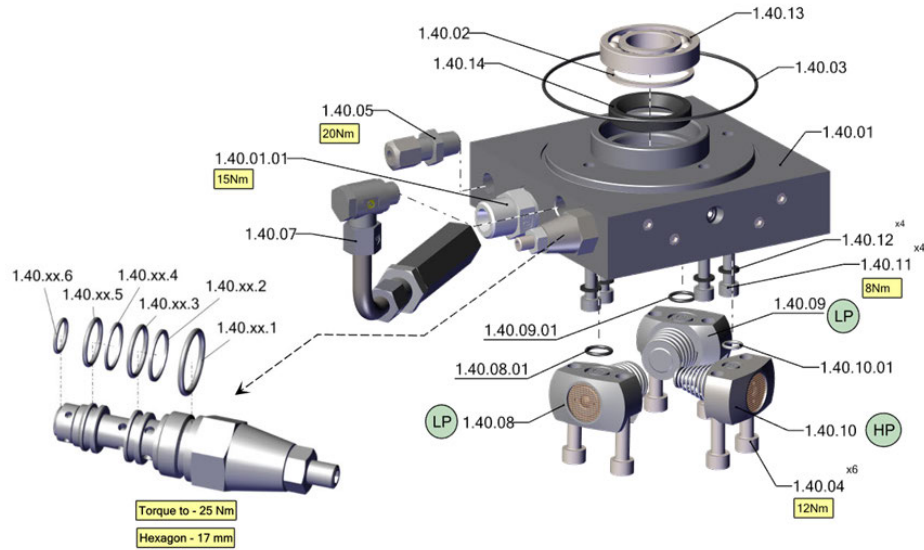

Before dismantling the shut-off valve, unload the spring by unscrewing the regulating screw.

Ref. item 1.40.01 Attention: different version for 115V/230V

Item	Quantity	Name	Type	Part. No.
1.40.01	1	pump flange	(115V/230V) pump	M-109616
1.40.01	1	screw in socket	GE08SREDOMPCF	M-106528
1.40.02	1	retaining ring	J35x1,5- DIN472	M-106245
1.40.03	1	o-ring	87x1,5-70 NBR	M-106737
1.40.04	6	cylinder head screw	M6x25-12.9-galv.	M-106092
1.40.05	1	max. pressure valve	DBT 1,5-750	M-100958
1.40.06	1	cut off valve	ASE	M-103363
1.40.xx.1	1	o-ring	14x1,5-90NBR	M-106661
1.40.xx.2	1	support ring	11,2/13x0,7-POM	M-106479
1.40.xx.3	1	o-ring	10,3x1,2-90NBR	M-106641
1.40.xx.4	1	support ring	10,2/12x0,6-POM	M-106481
1.40.xx.5	1	o-ring	10x1,2-90NBR	M-106642
1.40.xx.6	1	o-ring	7x1-90NBR	M-106623
1.40.07	1	o-ring	10,3x1,2-90NBR	M-106641
1.40.08	1	support ring	10,2/12x0,6-POM	M-106481
1.40.08.01	1	o-ring	9x1,5-90NBR	M-106637
1.40.09	1	o-ring	7x1-90NBR	M-106623
1.40.09.01	1	max. pressure valve	DBT 1,5-750	M-100958
1.40.10	1	low-pressure-pump, compl	PE 1-05 (HP)	M-100974
1.40.10.01	1	o-ring	6x1,5-90NBR	M-106614
1.40.11	4	cylinder head screw	M5x32-8.8-galv.	M-108689
1.40.12	4	sealing ring	5x9x1 WE DIN 7603	M-106843
1.40.13	1	ball bearing	16004	M-105867
1.40.14	1	oil seal	20x35x6-BA	M-106446

VALVE BLOCK

ITEM 2

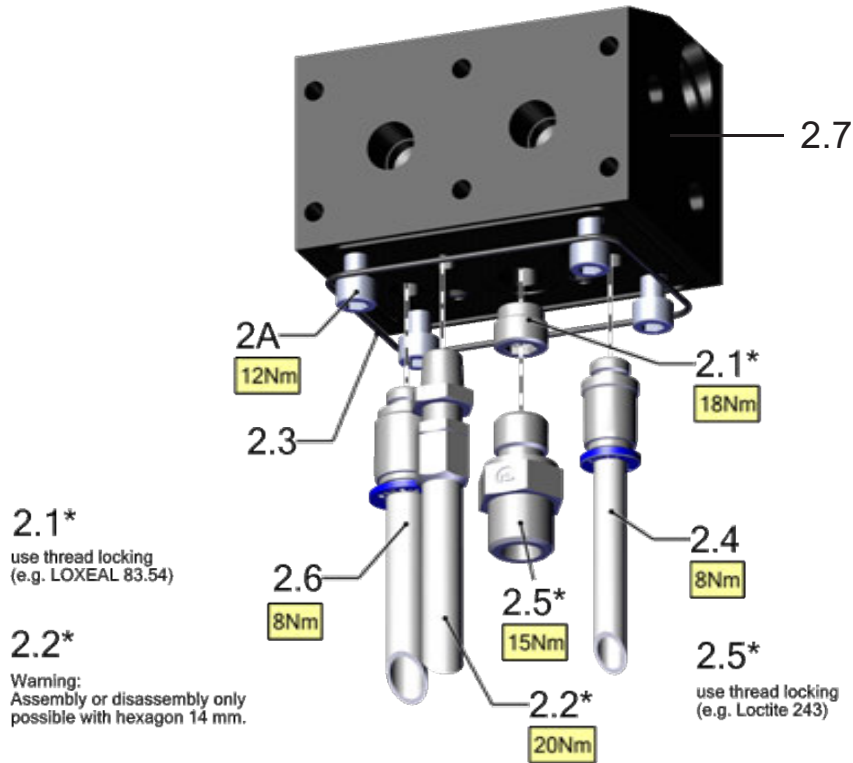

Item	Quantity	Name	Type	Part. No.
2	1	valve block complete	NG4	M-110234
2.1	1	check valve	RVB 6	M-100657
*2.2	1	pressure valve	DBT 1,5-100/110	M-103502
2.3	1	o-ring	80x1,5-70NBR	M-106734
2.4	1	tank pipe	G 1/8"-8/6	M-109714
2.5	1	screw in socket	GE08SREDOMDCF	M-106528
2.6	1	tank pipe	G 1/8"-10/8	M-109078
2.7	1	bare valve	Block	M-113292

2A	4	cylinder head screw (order seperately)	M6x16-ISO4762-8,8-galv	M-106798
----	---	--	------------------------	----------



Torque - 20Nm
Hexagon - 14 mm

Warning:
This Valve is adjusted by the factory.
The Manipulation of the adjustment may cause damage to the system and / or personal injury.
Assembly or disassembly only possible with 14mm hex wrench.

TORQUE VALVE

ITEM 3 - RELIEF VALVE ASSEMBLY

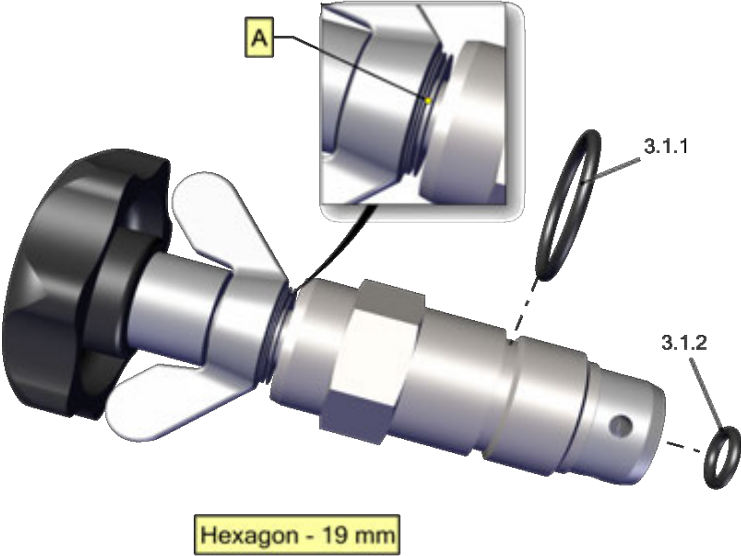

Advice: In case of pressure loss a pressure of 700 bar (10.000 psi) can be reached by removing some shim rings ("A").

SEAL KIT FOR TORQUE VALVE

ITEM 3.1

Part No. for complete Seal Kit: M-110950

Item	Quantity	Name	Type	Part. No.
3.1.1	1	o-ring	16x1,5-90 NBR	M-106672
3.1.2	1	o-ring	6x1,5-90 NBR	M-106614

SELNOID VALVE PUMP ASSEMBLY

ITEM 4

115V - SV-E4-W1X-C-O

Part No. M-111094

230V - SV-E4-W2X-C-O

Part No. M-111095

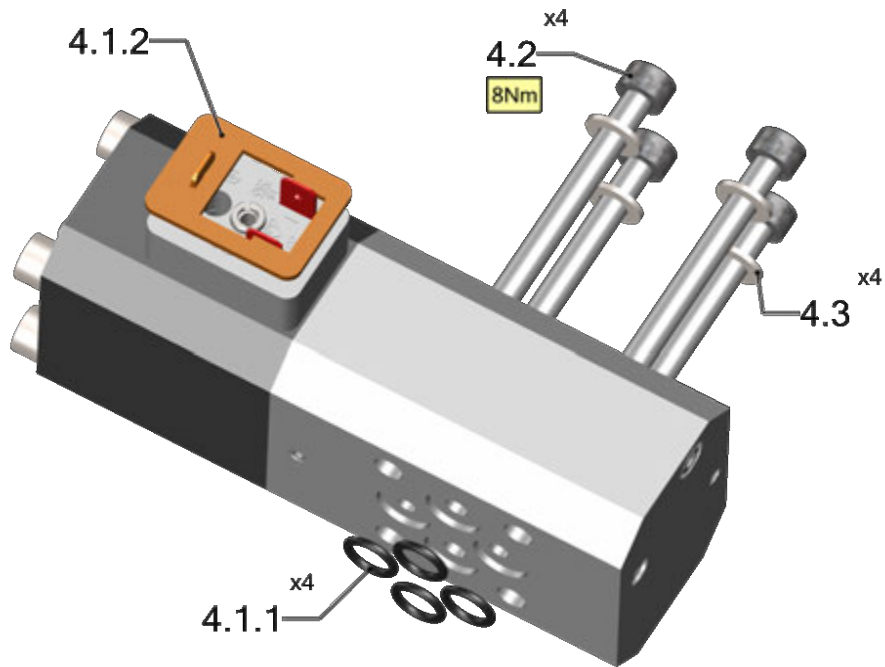

SEAL KIT FOR MAGNETIC VALVE

ITEM 4.1

Part No. M-103528

Item	Quantity	Name	Type	Part
4.1.1	4	o-ring	7x1,5-90 NBR	M-106622
4.1.2	1	seal	GM 207-3	M-103791

order seperatly

4.2	4	cylinder head screw	M5x45-10.9-galv.	M-108695
4.3	4	washer	5.3-DIN125-A2	M-106872

PRESSURE GAUGE

ITEM 5

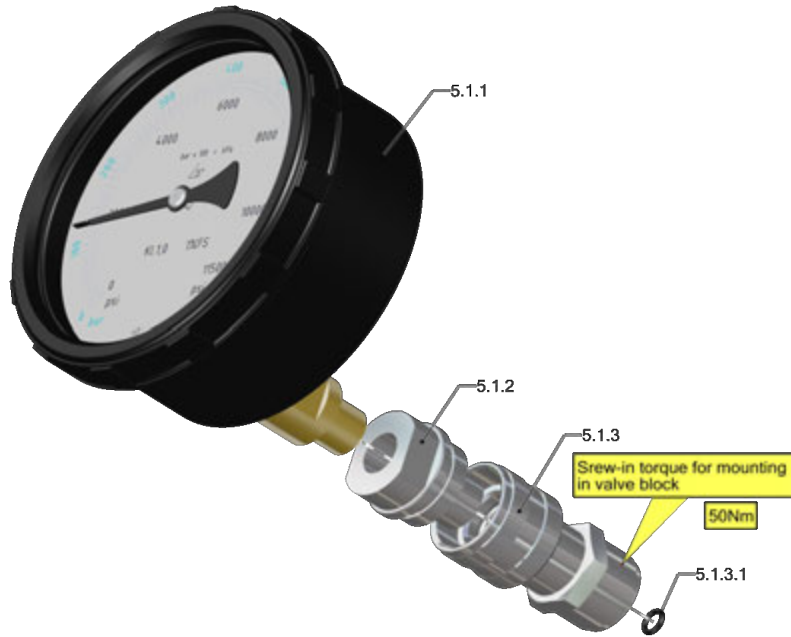

SEAL KIT FOR GAUGE

ITEM 5.1

Item	Quantity	Name	Type	Part. No.
5.1.1	1	pressure gauge	WIKA	PBG-2A-No Flange
5.1.2	1	male coupler		HC-M-200
5.1.3	1	pressure gauge adapter	Skidmore	M-109032
5.1.3.1	1	o-ring	5x1.5-90NBR	M-106609

ELECTRIC CONTROL ASSEMBLY

ITEM 6

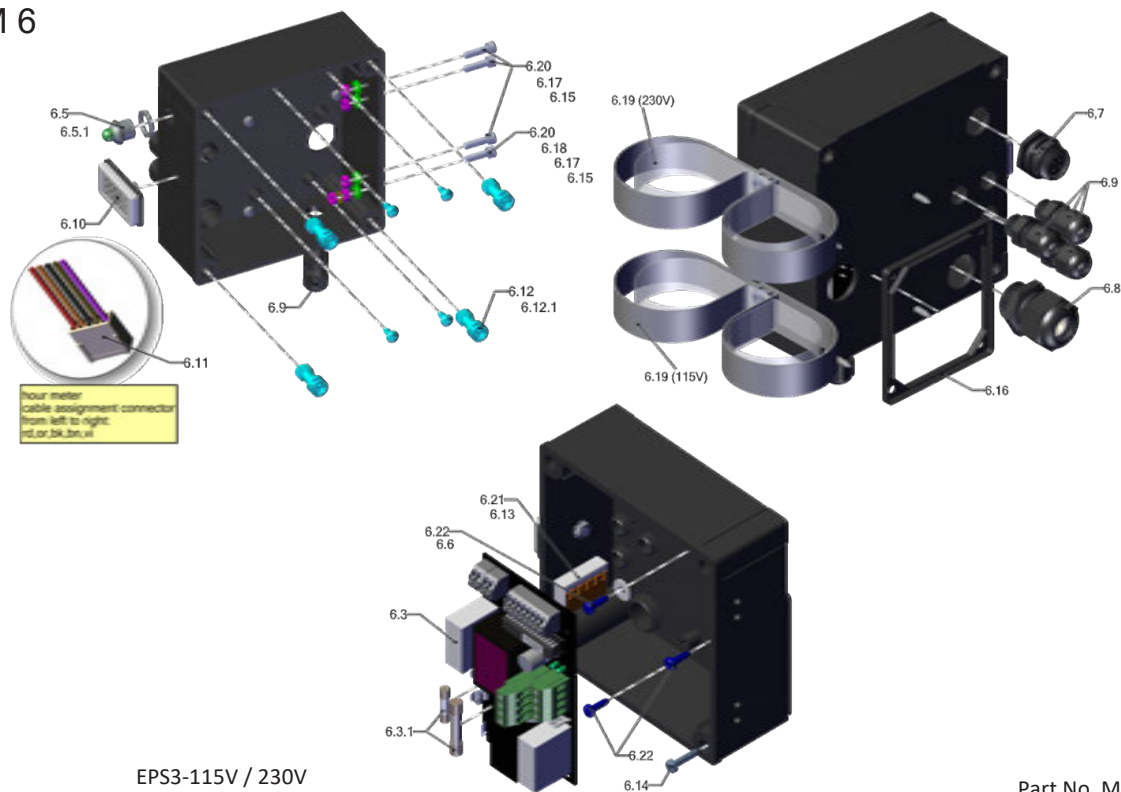

EPS3-115V / 230V

Part No. M-111114

Item	Quantity	Name	Type	Part. No.
6.1	1	cover complete with housing cover, LED and PG-screwings		M-111012
6.2	1	housing cover		M-111007
6.3	1	circuit board	EPS3	M-111009
6.3.1	1	fuse-set	EMAX/EMINI 115/230	M-111119
6.5	1	LED, green-OR		M-102218
6.5.1	1	locknut	M12x0,75/Ms	M-104108
6.6	1	washer	A4,3-galv. DIN 9021	M-106239
6.7	1	device socket remote control	PX0412/04s (AE)	M-111205
6.8	1	cable gland	M20, black	M-104380
6.9	4 (3)	cable gland	M12, black	M-104343
6.10	1	hour meter (connector see item 6.11)		M-111011
6.11	1	connector (for item 6.10)	WTB/5 pole/female plug	M-105340
6.12	1	screw set	Fibox MBS BLH (black)	M-105259
6.12.1	4	self tapping screw	M3,9 x 9.5 galv. ISO 14585c	M-106338
6.13	1	earthing cable		M-102190
6.14	1	self tapping screw	3,5x19 galv. ISO14585c	M-106342
6.15	4	sealing ring	M4-Polyamid	M-106436
6.16	1	sealing for clamp box		M-103786
6.17	5	hex nut	M4-8 galv. ISO4032	M-106932
6.18	1	toothed washer	A-4.3 galv. DIN6797	M-106920

Ref. item 6.19 & 6.20 Attention: different version for 115V/230V

6.19	4	115V tensioning belt	Ø55	M-101880
6.19	4	230V tensioning belt	Ø45	M-101925
6.20	4	cylinder head screws	M4x18-8 galv ISO4762	M-106068
6.21	1	connection clamp		M-105532
6.22	3	self tapping screw	3.5x13 galv ISO1458c	M-106341
6.23	3	locking screw	M12x1,5, black	M-105542

REMOTE CONTROL PENDANT

ITEM 7

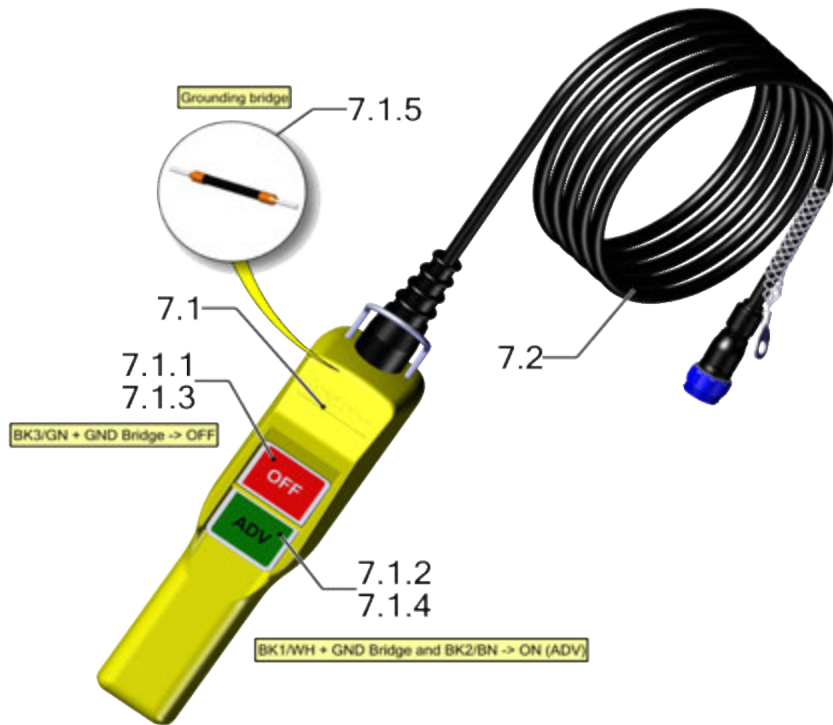

Item	Quantity	Name	Type	Part. No.
7	1	remote control compl	TorcUp-15ft	M-110204
consisting of:				
7.1	1	remote control (hand part)		M-111198
7.1.1	1	Sticker "OFF"		M-110237
7.1.2	1	Sticker "ADV"		M-110238
7.1.3	1	contact element	1NC	M-104659
7.1.4	1	contact element	1NO	M-104660
7.1.5	1	grounding bridge		M-109450
7.2	1	cable, compl.	15ft	M-111194

OIL RESERVOIR

ITEM 9

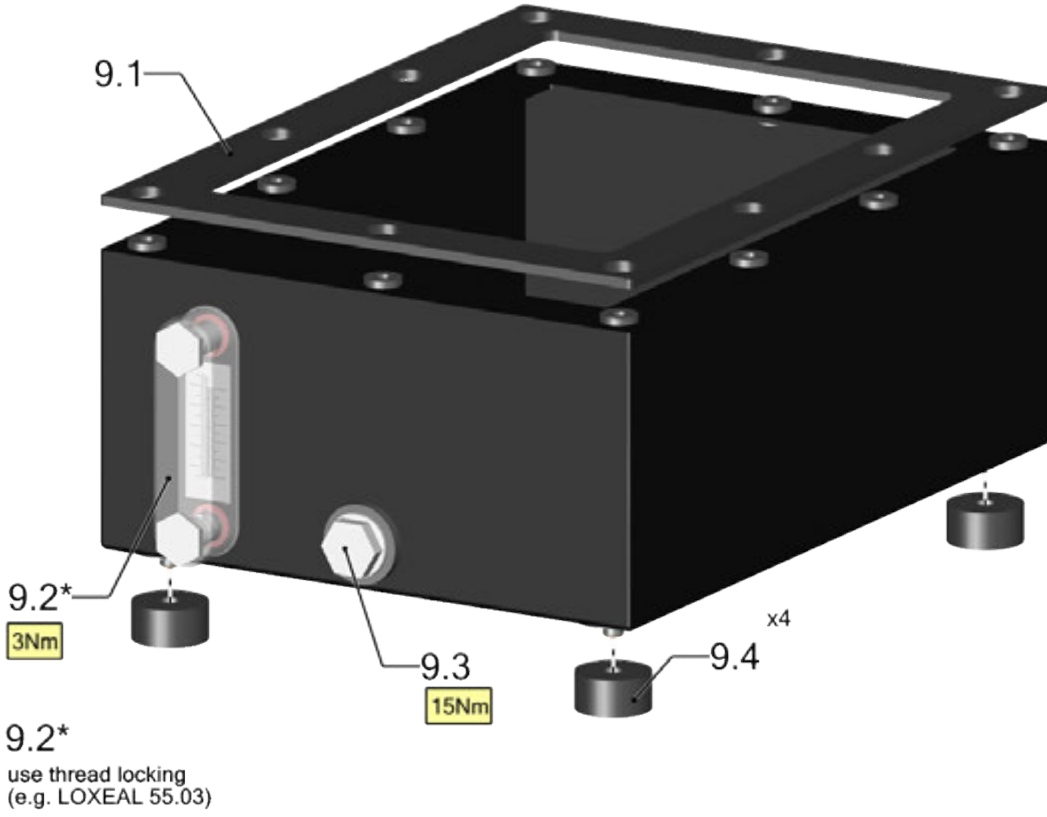

Item	Quantity	Name	Type	Part. No.
9.1	1	seal		M-111029
9.2	1	oil level indicator	SLVT-76 (M10)	M-104829
9.3	1	Plug	GN 738 - G1/2", mag, bk	M-104866
9.4	4	Rubber Feet	ø30/H=15/M8i	M-103671

CARRY HANDLE

ITEM 15

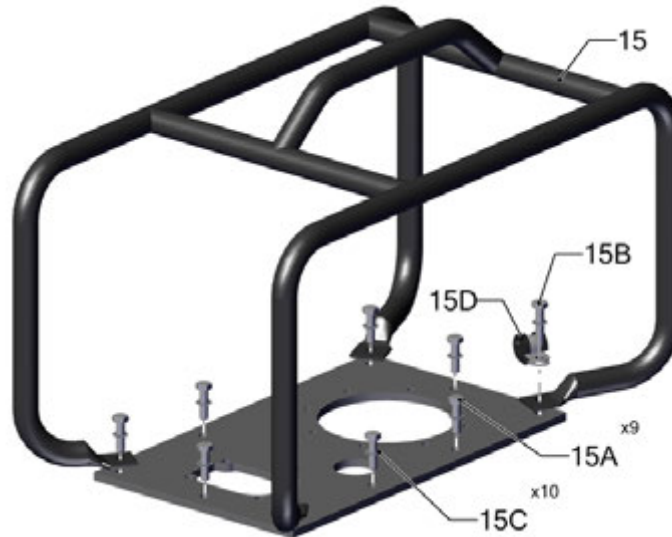

Item	Quantity	Name	Type	Part. No.
15	1	carry handle		M-111032
order parts separately				
15A	9	hexagon screw	M6x22-8.8 galv. ISO 4017	M-106129
15B	1	hexagon screw	M6x28-8.8 galv. ISO 4017	M-106131
15C	1	washer, pump deck, buna bonded	MCM94708A313	M-106277
15D	1	pipe clip	RSGU 1.10/15	M-104959

COUPLINGS

ITEM 20

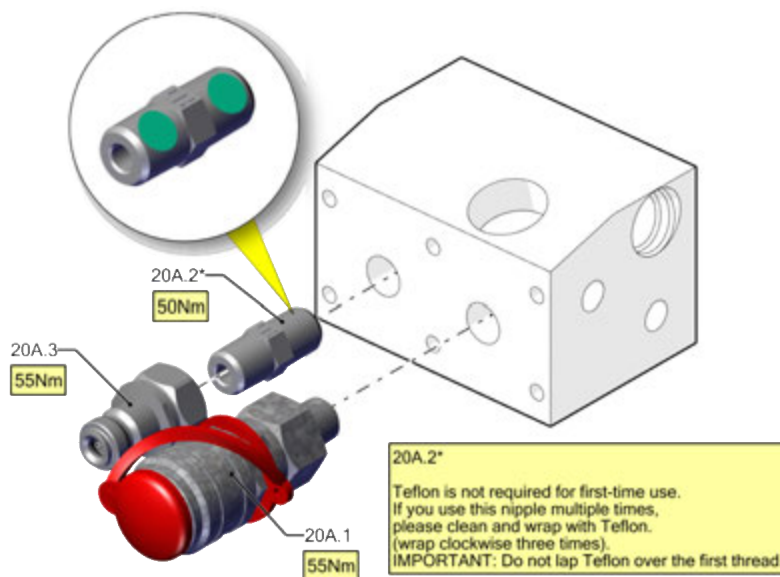

Item	Quantity	Name	Type	Part. No.
20A.1	1	female coupler	115/1/4"NPT AG	HC-F-400
20A.2	1	double 1/4" fitting	1/4" NPTF	F004004
20A.3	1	male nipple	115/1/4"NPT IG/HF	HC-M-100

SUBASSEMBLY 4-PORT-MANIFOLD

ITEM 21

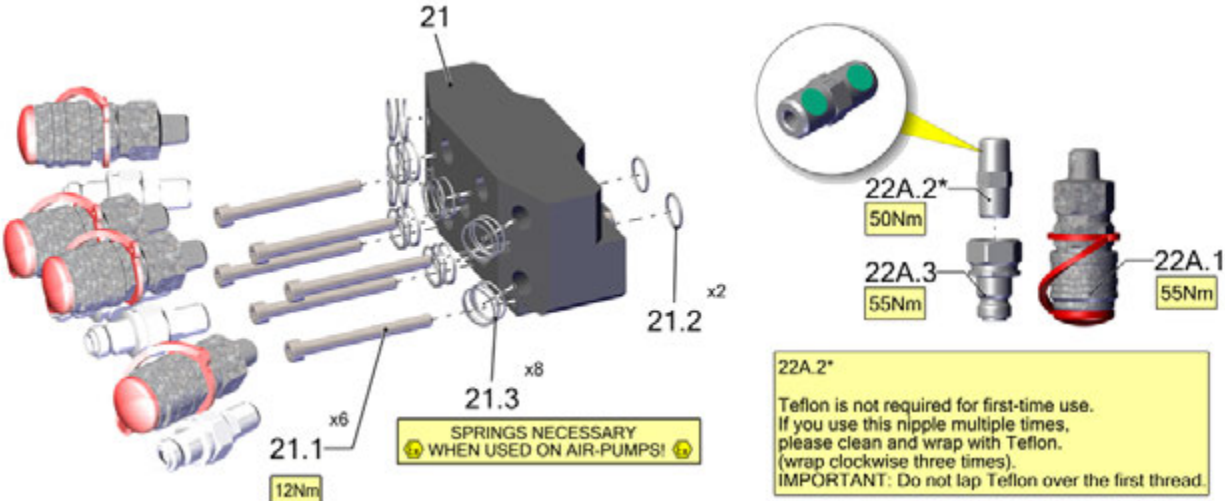

Item	Quantity	Name	Type	Part. No.
21	1	adapter 4-port-manifold, set		EMAX/AMAX Manifold
21.1	6	cylinder head screw	M6x60-10.9 galv.ISO 4762	M-111614
21.2	2	o-ring	14x1,5-90NBR	M-106661
21.3	8	spring		M-106414

order parts seperately

Item	Quantity	Name	Type	Part. No.
22A		couplings		
22A.1	4	female coupling	GE08SREDOMPCF	HC-F-400
22A.1	4	double nipple	J35x1,5- DIN472	F004F004
22A.3	4	male coupling	87x1,5-70 NBR	HX-M-100

ELECTRICAL CONNECTION DIAGRAM

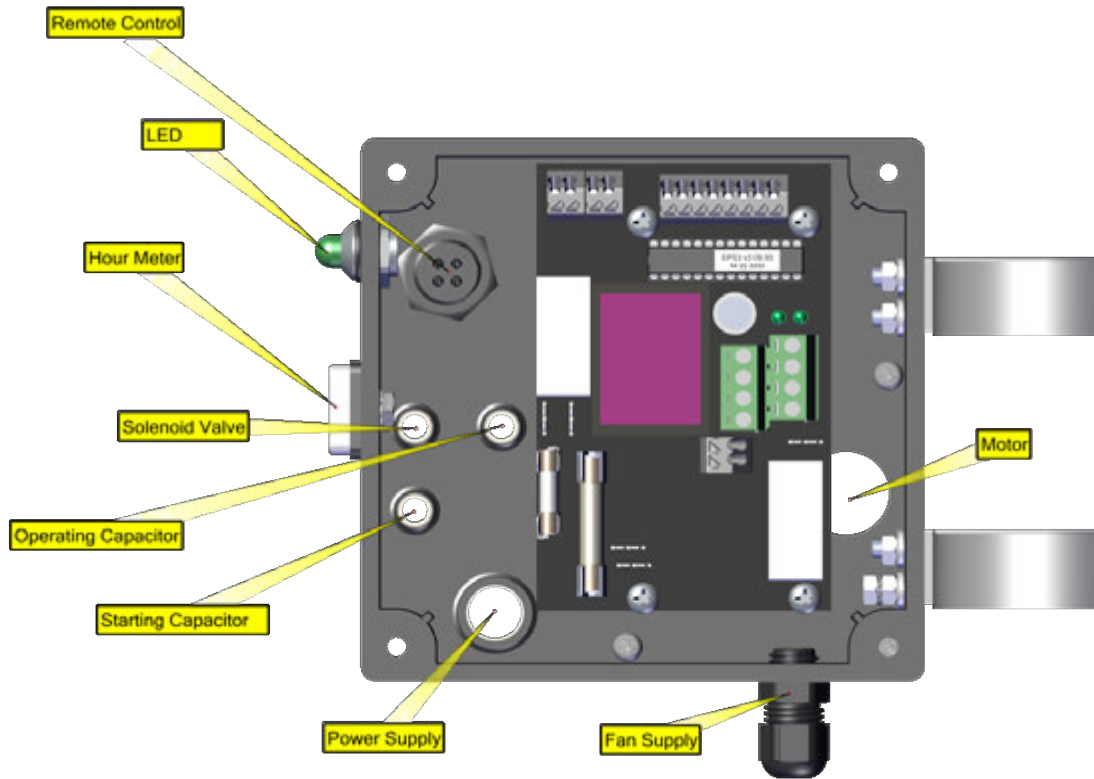

Component	Cable colour	Clamp	Component	Cable color	Clamp
Motor	black BK	X1.8 (C. b.)	Operating Capacitor	brown BN	X1.1
	white WH	X1.5 (C. b.)		blue BU	X1.4
	red RD	X1.6 (C. b.)		green/yellow GNYE	PE
	blue BU	X1.7 (C. b.)	Starting Capacitor	brown BN	X1.2
	yellow YE	P2A		blue BU	X1.3
	yellow YE	P3		green/yellow GNYE	PE
Power Supply	green/ green/yellow GNYE	PE	LED	black BK	X4.2 (-)
	white/blue WH/BU	P1		red RD	X4.1 (+)
	black/brown BK/BN	P2	Fan Supply (if present)	black1 BK1	X3
grey GY	X5.auto	black2 BK2		X3	
Remote Control	brown BN	X5.off	Hour Meter	red RD	LK1 (RD)/PDZ1
	blue BU	X5.on		orange OR	LK1 (RD)/PDZ1
	black BK	X5.com		black BK	LK2 (BK)/PDZ1
				brown BN	LK2 (BK)/PDZ1
Solenoid Valve	violet VI			LK2 (BK)/PDZ1	
	blue BU	X2			
	brown BN	X2			
	green/yellow GNYE	PE			

HYDRAULIC SCHEMATIC DIAGRAM

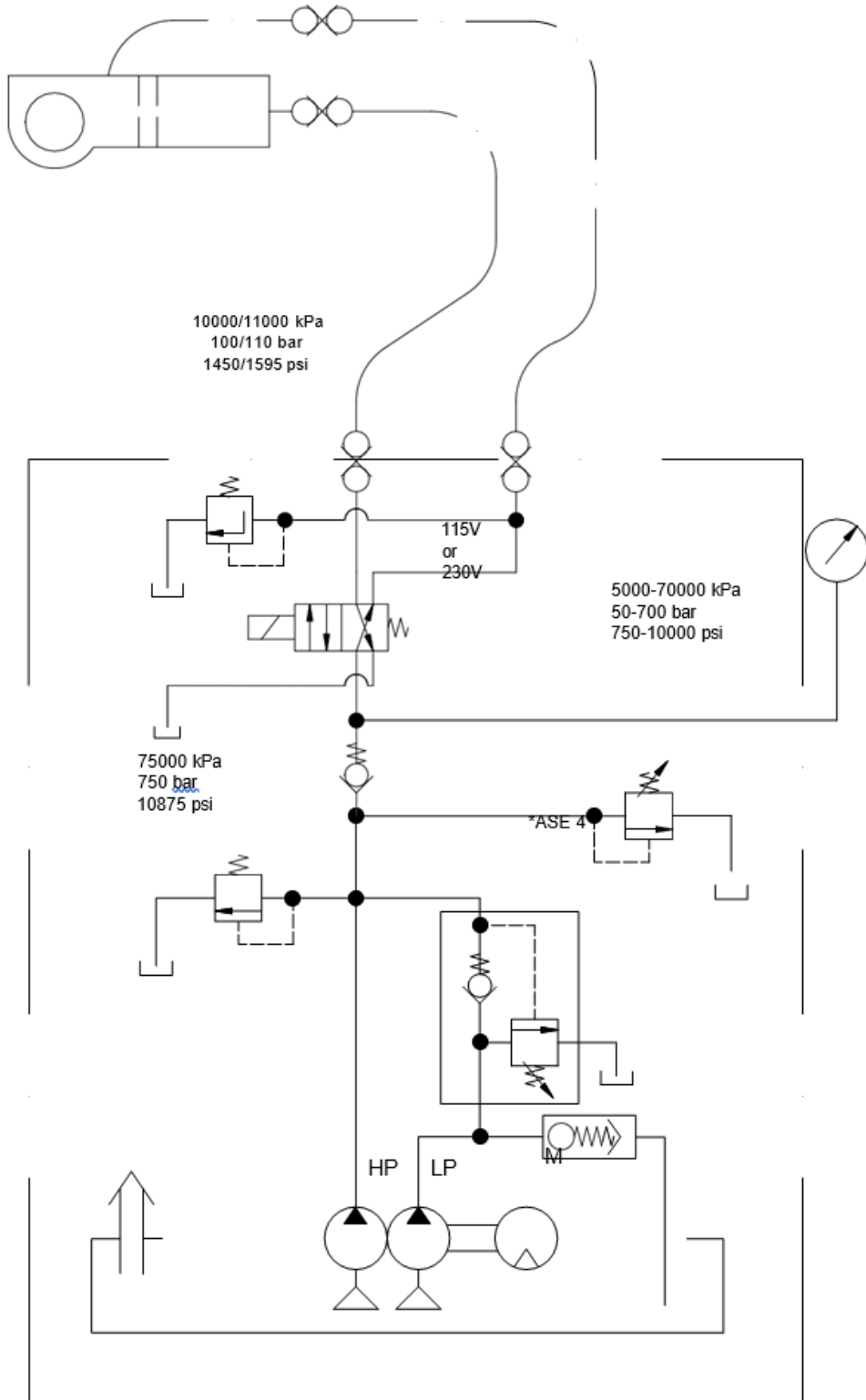

Part Number: EMAX/AMAX-QUADKIT-Q

Description: 4-Tool Quad Port Kit, installed with TorcUP QUICK CONNECT Couplers

Kit includes the following items:

- EMAX/AMAX-MANIFOLD (Qty 1)
 - 4-Tool Manifold (Qty 1)
 - Mounting Screws (Qty 6)
 - O-Rings (Qty 2)
- F004F004 fittings (Qty 3)
- HC-M-100 Quick Connect Nipple (Qty 3)
- HC-F-400 Quick Connect Couplers (Qty3)

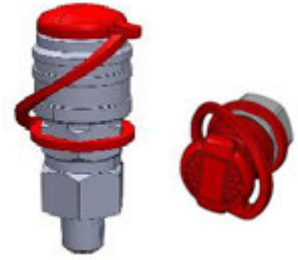

Part Number: EMAX/AMAX-QUADKIT-T

Description: 4-Tool Quad Port Kit, installed with THREADED or SCREW type Couplers

Kit includes the following items:

- EMAX/AMAX-MANIFOLD (Qty 1)
 - 4-Tool Manifold (Qty 1)
 - Mounting Screws (Qty 6)
 - O-Rings (Qty 2)
- F004F004 fittings (Qty 3)
- HC-S-200 Screw Type coupler set (Qty 3)



Installation of QUADKIT to an existing pump.

1. Remove existing couplers and fittings (fig 1) from Valve Block. (Keep for Reuse)
2. Clean oil and remove debris from Valve Block face surface.
3. Install nipple and couplers on to manifold (fig 2)
 - ADVANCE (Top Row) use the Female couplers
 - RETRACT (Bottom Row) us the fittings and male nipples.
 - Use Teflon tape on threads.
 - Torque to 37 lbf-ft / 50Mn
4. Use a small amount of grease to hold the O-Rings to the manifold. (fig 3)
5. Mount manifold assembly to Valve Block, using 6 socket head cap bolts. (fig 4)
 - Hand snug all bolts
 - Torque bolts to 9 lbf-ft / 12Nm
6. Pressurize pump to ensure no oil leaks.

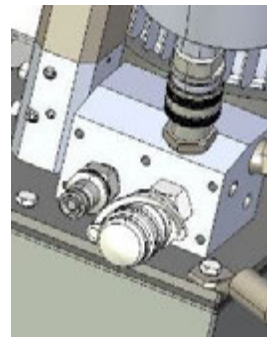

fig 1

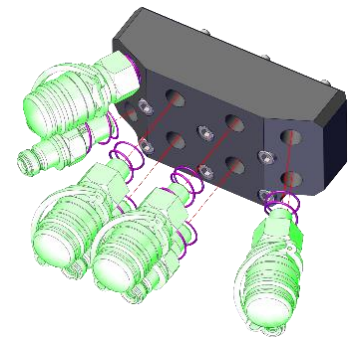

fig 2

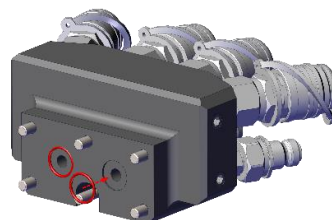

fig 3

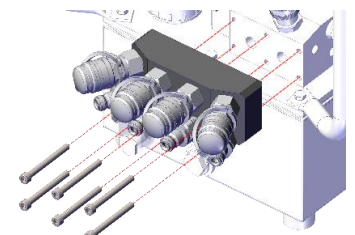

fig 4

