

HYDRAULICAL SPREADERS

Loads are lifted perpendicularly!



SR15



TL07



SR07

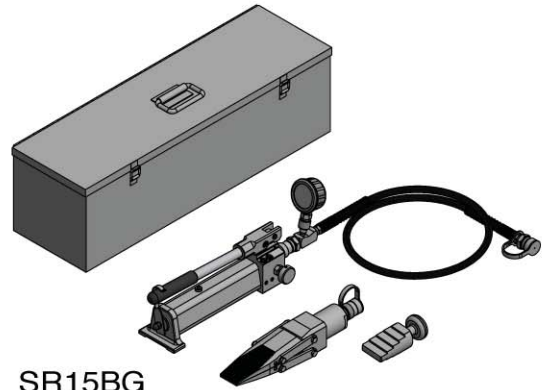

SR15BG

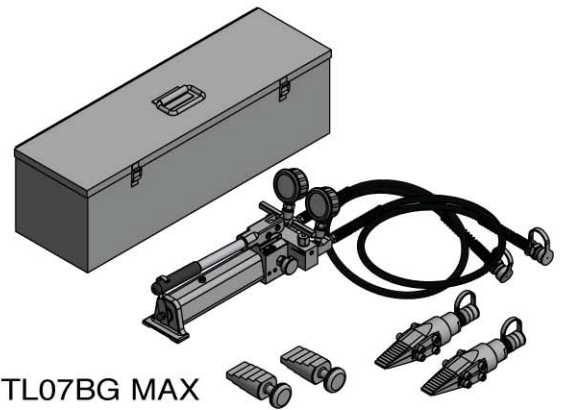

TL07BG MAX

FEATURES

- Ideal for numerous industrial maintenance repair jobs.
- Accurate height adjustments (for instance shaft alignment) can easily be executed by one person.
- Easy, light and very practical to use.
- Particularly suitable when available space is very limited. from 5 to 40 mm.
- Due to the reduced thickness of the jaws, made of high quality hardened steel, these multi-functional wedges can be used for jobs where working space is extremely limited.
- Package models are also available, please contact with the authorized distributors for details.

SR07-TL07

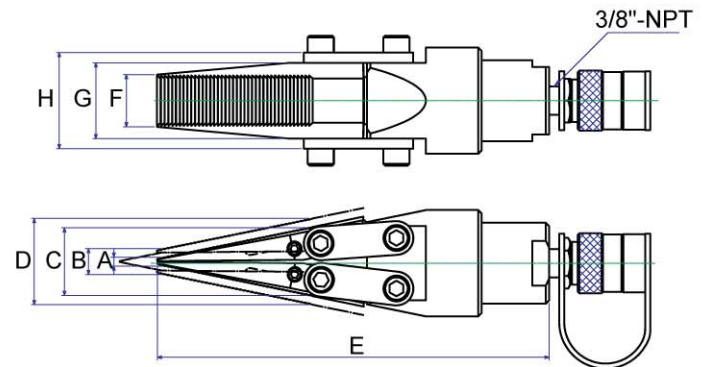

SPECIFICATIONS

Model No.	Capacity Tons	Spread (mm)		Stroke (mm)	C (mm)	D (mm)	E (mm)	F (mm)	G (mm)	H (mm)	Weight (kgs)
		Min - A	Max - B								
SR07	15	5	15	25	40	50	232	31	45	57	3.3
SR07BG	15	5	15	25	40	50	232	31	45	57	3.3
SR07BG MAX	15 x 2	5	15	25	40	50	232	31	45	57	3.3
TL07	15	5	15	25	36	46	232	31	45	57	3.3
TL07BG	15	5	15	25	36	46	232	31	45	57	3.3
TL07BG MAX	15 x 2	5	15	25	36	46	232	31	45	57	3.3
SR15	25	7	23	65	42.5	59	342	50.5	70	82	7.8
SR15BG	25	7	23	65	42.5	59	342	50.5	70	82	7.8
SR15BG MAX	25 x 2	7	23	65	42.5	59	342	50.5	70	82	7.8