

HEAVY-DUTY HAND PUMPS



MODEL: P90 SERIES
Single & Dual speed models
Max. working pressure:
700 - 1000 bar

FEATURES

- High pressure hydraulic hand pumps are the solution for tough jobs.
- Reduced handle effort and ergonomic grip for less operator fatigue.
- Dual-speed operation for fast and easy operation.
- Vent free reservoir eliminates spills.
- Quick grip handle allows for easy transport.
- Integral reservoir with over-pressurization protection.
- Chrome plated plunger and wiper system for durable, long lasting performance.

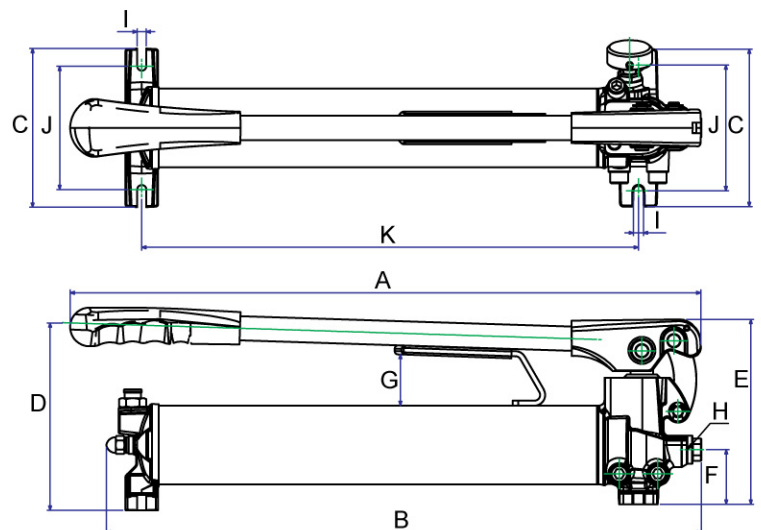

SPECIFICATIONS

Model No.	Pressure Rating (bar)		Oil Capacity (c.c.)	Usable Oil Capacity (c.c.)	Oil Volume per stroke (c.c.)		A (mm)	B (mm)	C (mm)	D (mm)	E (mm)	F (mm)	G (mm)	H (mm)	I (mm)	J (mm)	K (mm)	Weight (kgs)
	1st stage	2nd stage			1st stage	2nd stage												
P901	20	700	450	300	19.4	1.2	447	369.5	140	163	164	48.5	45	3/8"NPT	8	112	282	6.5
P902	20	700	850	750	19.4	2.8	560	530	140	167	164	48.5	45		8	112	442	7.8
P903	20	700	1600	1400	19.4	2.8	633	597.5	140	170	164	48.5	36.5		8	112	510	10
P904	27.5	700	2500	2200	39.5	2.8	633	578	150	208	195	55	46		8	121	502	13.5
P904D	27.5	700	2500	2200	35.6	2.8	633	609	150	208	195	38	47		8	121	502	15
P905	20	1000	850	750	19.4	1.2	560	530	140	167	164	48.5	45	8	112	442	7.8	