

Model No.: HP35 & HP35D



HP35

HP35D

1.0 These instructions must be read and followed carefully.

2.0 Inspect the pumps upon arrival thoroughly. The pumps might be damaged from the carriers' carelessly transportation and delivery.

3.0 SAFETY NOTES

- ◆ These pumps should only be used by qualified, trained persons who are familiar with this equipment.
- ◆ Never rely on the pumps to support and/or hold the loads.
- ◆ To avoid personal injury, keep hands and feet away from cylinder and workpiece during operation.
- ◆ Do not exceed equipment ratings. Never attempt to lift a load weighing more than the capacity of cylinder. Overloading causes equipment failure and possible personal injury. The cylinders are designed for a max. pressure of 700 bar (10,000 psi). Do not connect a jack or cylinder to a pump with a higher pressure rating.
- ◆ Never Set the relief valve pressure above 725 bar (10,500 psi). Serious personal Injury could result if this maximum limit is exceeded. Damage to pump and components may also occur.
- ◆ Keep hydraulic equipment away from flames and heat. Excessive heat will soften packing and seals, resulting in fluid leaks. Heat also weakens hose materials and packing. For optimum performance don't expose equipment to Temperature of 65°C (150°F) or higher. Protect hoses and cylinders from weld spatter.

HOSES

- ◆ Should a hydraulic hose ever rupture, burst or need to be disconnected immediately shut off the pump and shift the control valve to release all pressure. Never grasp a leaking pressurized hose with your hands.
- ◆ Always keep the hose away from fire, sharp surfaces, heavy impact and extreme heat or cold. Never kink, twist, curl or bend the hose so tightly that the oil flow within will be blocked or reduced.

- ◆ Always inspect the hose for wear periodically, as any of these conditions can damage the hose and possibly result in personal injury.
- ◆ Hose material and coupler seal must be compatible with the hydraulic fluid used. Hose also must not come in contact with corrosive materials such as creosote-impregnated objects and some paints. Never paint a coupler, hose deterioration due to toxic materials.
- ◆ Never use the hose to move attached equipment. Stress can damage the hose and possibly cause personal injury.

4.0 PRODUCT INFORMATION

Pump Model	Max. Pressure Rating (bar)		Oil Volume Per Stroke (c.c.)		Usable Oil Capacity (c.c.)	Weight (kg)
	1 st Stage	2 nd Stage	1 st Stage	2 nd Stage		
HP35	28	700	30	3	3500	16.5
HP35D	28	700	30	3	3500	16.8

5.0 INSTALLATION

5.1 Connecting the pump

1. Remove shipping plugs from pump outlet ports.
2. Connect hoses to pump. To seal threads, use thread sealer or seal paste or seal tape. **When using seal tape, apply tape one thread back from the end of fitting to prevent tape mesh from entering the hydraulic system.**
3. Install a pressure gauge in-line from the pump for added safety and better control.
4. Connect the hoses to your cylinder or tool. For single-acting cylinders, connect one hose from the pump to the cylinder.

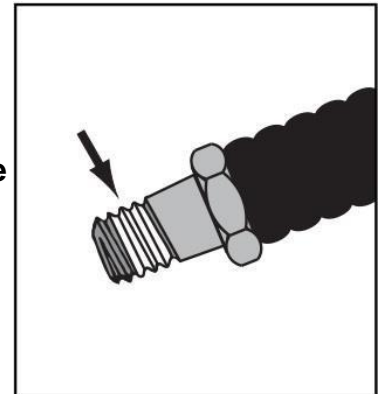

5.2 Venting

a) Model No.: HP35

Must ensure the air vent from the pump before operating the pump. The screw of oil fill plug should be loosened for air venting before using the pump.

b) Model No.: HP35D

This model is designed for non-vented operation. The oil fill plug can be loosened needed to vent air from the system but should be fully installed before using the pump.

IMPORTANT

To prevent contaminants from entering the hydraulic system, do not operate pump with oil fill plug loosened or removed.

5.3 Pump Position

The pump may be used in either the horizontal or vertical position. When operated in the vertical position, hose end of pump must be pointed down, or the pump will pick up air and will not build up pressure properly.

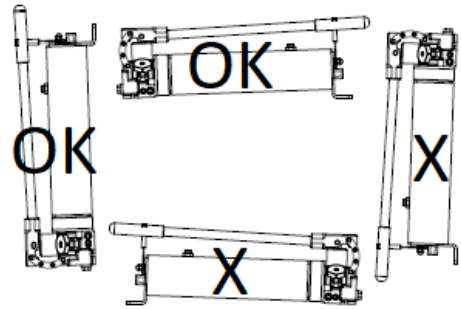

6.0 OPERATION

6.1 Before using the pump

1. Inspect all system fittings and connections to be sure they are tight and leak free.
2. Check oil level in reservoir and add oil if needed. Refer to instruction in Section 8.1.
3. Read and understand the following precautions before operating pumps:

❗ **BE CAREFUL:** In certain situation the pump handle can “spring back”. Always keep your body to the side of the pump, away from the line of force of the handle.

❗ **BE CAREFUL:** Keep hands and fingers away from pinch point area between pump handle and lifting handle, when operating the pump handle.

⚠ **CAUTION:** Never add extensions to pump handle. Extensions cause unstable pump operation.

⚠ **CAUTION:** To prevent mechanical damage, do not pull on pump handle after it has reached the end of its travel. Do not apply side force to pump handle.

❗ **BE CAREFUL:** At the stage of high pressure, take short strokes to reduce handle force. Maximum leverage is obtained in the last 5 degrees of stroke.

6.2 Two Stage Flow

Under no loading, the pump operates in the high flow stage for fast advance. When the load is contacted, the pump shifts automatically to the low flow stage to build up pressure. After the pump shifts, priming takes less force.

Note: For the best performance, priming pump handle at moderate speed during the high flow stage. Fast handle speed in the high flow stage will prevent the pump from delivering full volume of oil.

6.3 Pump Operation – HP35

This model is designed for use with single-acting cylinders and is equipped with an integral release valve.

1. Only close the release valve by turning knob clockwise until it stops.
2. Open the release valve by turning knob counter-clockwise to release the pressure and allow oil to flow back to the reservoir.

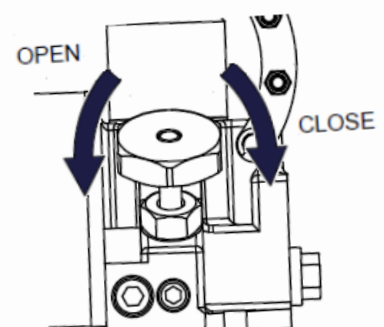

CAUTION: If release valve knob is difficult to turn or becomes stuck, discontinue using pump immediately. Have pump inspected and repaired by POWERRAM authorized dealers.

6.4 Pump Operation – HP35D

This model is equipped with a 2-way, 3-position control valve and designed for use with double-acting cylinder. Position lever on 2-way valve to select functions as follows.

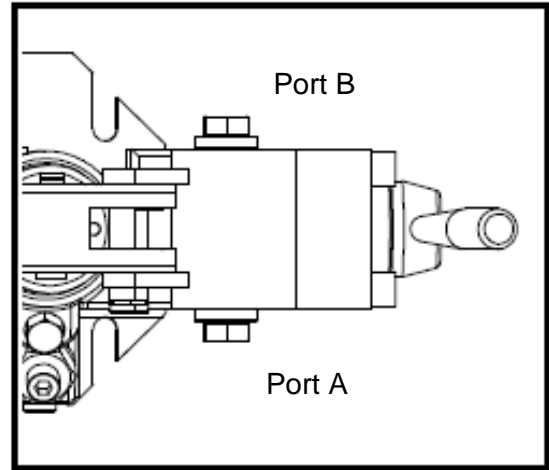
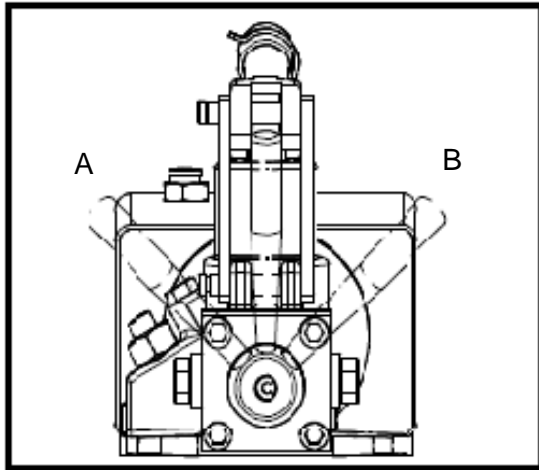

- (A) Flow directed to port “A”; Port “B” returns flow to the reservoir.
- (N) Neutral – Ports “A” and “B” open to the reservoir.
- (B) Flow directed to port “B”; port “A” returns flow to the reservoir.

Valve Function	Use with Cylinder Type
<div style="display: flex; justify-content: space-around;"> <div style="text-align: center;"> <p>POSITION "A"</p> </div> <div style="text-align: center;"> <p>CENTER POSITION</p> </div> <div style="text-align: center;"> <p>POSITION "B"</p> </div> </div>	<p>Single & double acting</p>
Valve Type	
<p>2-way, 3-position, pump mounted manual detent</p>	

Max. Capacity: 700 Bar (10,000 PSI)

CAUTION! Valve contains no load holding device. Be sure load is supported by blocking, mechanical stands or other appropriate supports before moving valve lever to the neutral (N) Position.

7.0 AIR BLEEDING

Removing air from the hydraulic system will help the cylinder to advance and retract smoothly.

7.1 Pump W/ Single-Acting Cylinder

1. Loosen and remove oil fill plug to provide reservoir venting during the following steps.
2. Fully close release valve.
3. Position pump in the horizontal position at higher level than cylinder.
4. Position cylinder with the plunger end down (up if using pull cylinder).
5. Operate pump to extend the piston of cylinder fully (retract if using pull cylinder).
6. Open release valve to retract cylinder (extend if using pull cylinder). This will force the trapped air to move up to the pump reservoir.
7. Repeat steps 2 through 6 as needed, until cylinder operation is smooth.
8. Add oil if necessary, see Section 8.1
9. Assemble oil fill plug back.

7.2 Pump W/ Double-Acting Cylinder

1. Loosen oil plug several turns to allow reservoir venting during the follows.
2. Position pump in the horizontal position as higher level then cylinder.
3. Put cylinder in horizontal position with ports above.
4. Advance and retract the piston of cylinder 2 to 3 times fully.
5. Repeat steps 2 through 4 as needed, until cylinder operation is smooth.
6. Add oil if necessary. See Section 8.1
7. Assemble oil fill plug back.

8.0 MAINTENANCE

8.1 Adding Oil to the pump

IMPORTANT: Always add oil with cylinders fully retracted (extended if pull cylinders) or the system will contain more oil than the reservoir capacity. Check oil level regularly and add oil if needed. Refer to the follows.

1. Place pump in the horizontal position on a level surface.
2. Remove oil fill plug from reservoir.
3. Check oil level. See Figure right. If oil level is low, add additional oil.

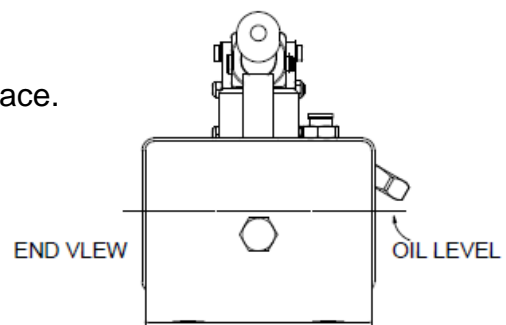

IMPORTANT: Do not overfill! Some air space must be present in reservoir to allow proper operation. If the reservoir contains too much oil, a vacuum will form, prevent oil flow when pump is operated.

4. Assemble oil fill plug back after oil added. Be sure the plug is fully tightened (not loose).
5. Remove air from system if necessary. See Section 7.0. Recheck oil level after air removed.

8.2 Lubrication

To extend pump life and improve performance, lubricate the handle pins regularly.

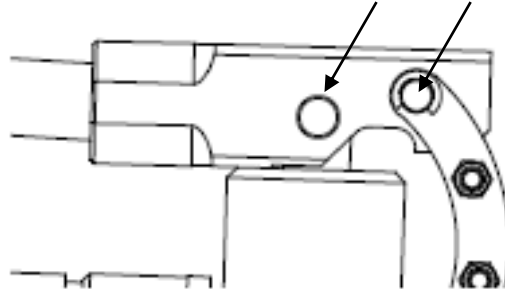

9.0 TROUBLESHOOTING GUIDE

A system failure may or may not be the result of a pump malfunction. To determine the cause of the problem is the key issue.

<u>PROBLEM</u>	<u>CAUSE</u>	<u>SOLUTION</u>
Cylinder does not advance, advances slowly or Advances difficultly	<ol style="list-style-type: none"> 1. System components leaking. 2. Lower fluid level in Reservoir. 3. Load is too heavy. 4. Air tapped into system. 5. Too much fluid in Reservoir. 6. Release valve not fully closed. 	<ol style="list-style-type: none"> 1. Check all connection are fully tightened. 2. Add oil. 3. Don't attempt to lift more than rated capacity. 4. Air bleeding per the instruction in Section 7.0. 5. Remove excess oil. 6. Close the release Valve fully.
Cylinder advances, but not holding pressure	<ol style="list-style-type: none"> 1. System components leaking. 2. Fluid leading past inlet or outlet checks. 3. Seals worn or leaking 	<ol style="list-style-type: none"> 1. Check all connection are fully tightened. 2. Contact with Authorized Dealers for service. 3. Contact with Authorized Dealers for service.
Pump handle has a "spongy" feel	<ol style="list-style-type: none"> 1. Air tapped into system. 	<ol style="list-style-type: none"> 1. Refer to Section <u>7.0 Air Bleeding</u>.

Model No.: HP80 & HP80D



HP80



HP80D

1.0 These instructions must be read and followed carefully.

2.0 Inspect the pumps upon arrival thoroughly. The pumps might be damaged from the carriers' carelessly transportation and delivery.

3.0 SAFETY NOTES

- ◆ These pumps should only be used by qualified, trained persons who are familiar with this equipment.
- ◆ Never rely on the pumps to support and/or hold the loads.
- ◆ To avoid personal injury, keep hands and feet away from cylinder and work piece during operation.
- ◆ Do not exceed equipment ratings. Never attempt to lift a load weighing more than the capacity of cylinder. Overloading causes equipment failure and possible personal injury. The cylinders are designed for a max. pressure of 700 bar (10,000 psi). Do not connect a jack or cylinder to a pump with a higher pressure rating.
- ◆ Never Set the relief valve pressure above 725 bar (10,500 psi). Serious personal Injury could result if this maximum limit is exceeded. Damage to pump and components may also occur.
- ◆ Keep hydraulic equipment away from flames and heat. Excessive heat will soften packing and seals, resulting in fluid leaks. Heat also weakens hose materials and packing. For optimum performance don't expose equipment to Temperature of 65°C (150°F) or higher. Protect hoses and cylinders from weld spatter.

HOSES

- ◆ Should a hydraulic hose ever rupture, burst or need to be disconnected immediately shut off the pump and shift the control valve to release all pressure. Never grasp a leaking pressurized hose with your hands.

- ◆ Always keep the hose away from fire, sharp surfaces, heavy impact and extreme heat or cold. Never kink, twist, curl or bend the hose so tightly that the oil flow within will be blocked or reduced.
- ◆ Always inspect the hose for wear periodically, as any of these conditions can damage the hose and possibly result in personal injury.
- ◆ Hose material and coupler seal must be compatible with the hydraulic fluid used. Hose also must not come in contact with corrosive materials such as creosote-impregnated objects and some paints. Never paint a coupler, hose deterioration due to toxic materials.
- ◆ Never use the hose to move attached equipment. Stress can damage the hose and possibly cause personal injury.

4.0 PRODUCT INFORMATION

Pump Model	Max. Pressure Rating (bar)		Oil Volume Per Stroke (c.c.)		Usable Oil Capacity (c.c.)	Weight (kg)
	1 st Stage	2 nd Stage	1 st Stage	2 nd Stage		
HP80	27.5	700	113	4	8000	24
HP80D	27.5	700	113	4	8000	25

5.0 INSTALLATION

5.1 Connecting the pump

1. Remove shipping plugs from pump outlet ports.
2. Connect hoses to pump. To seal threads, use thread sealer or seal paste or seal tape. **When using seal tape, apply tape one thread back from the end of fitting to prevent tape mesh from entering the hydraulic system.**
3. Install a pressure gauge in-line from the pump for added safety and better control.
4. Connect the hoses to your cylinder or tool. For single-acting cylinders, connect one hose from the pump to the cylinder.

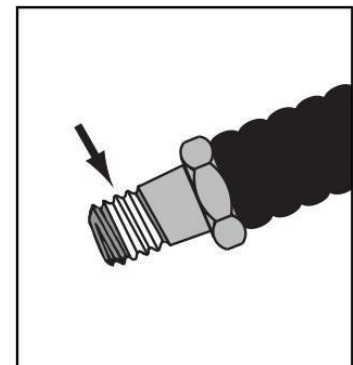

5.2 Venting

- a). Model No.: HP80 & HP80D

The reservoir of these series hand pumps are not vented. So need to loosen the vent screw for air venting prior to operating the pump.

- b). These models are designed for non-vented operation. The oil fill plug can be loosened if needed to vent air from the system but should be fully installed before using the pump.

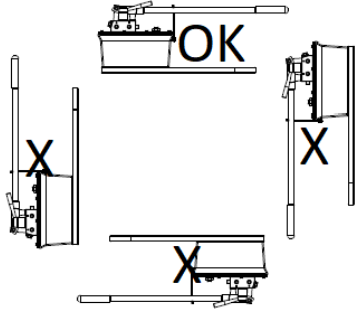

IMPORTANT:

To prevent contaminants from entering the hydraulic system, do not operate pump with oil fill plug loosened or removed.

5.3 Pump Position

These series hand pumps only can be used in the horizontal position.

6.0 OPERATION

6.1 Before using the pump

1. Inspect all system fittings and connections to be sure they are tight and leak free.
2. Check oil level in reservoir and add oil if needed. Refer to instruction in Section 8.1.
3. Read and understand the following precautions before operating pumps:

❗ **BE CAREFUL:** In certain situation the pump handle can “spring back”. Always keep your body to the side of the pump, away from the line of force of the handle.

❗ **BE CAREFUL:** Keep hands and fingers away from pinch point area between pump handle and lifting handle, when operating the pump handle.

⚠ **CAUTION:** Never add extensions to pump handle. Extensions cause unstable pump operation.

⚠ **CAUTION:** To prevent mechanical damage, do not pull on pump handle after it has reached the end of its travel. Do not apply side force to pump handle.

❗ **BE CAREFUL:** At the stage of high pressure, take short strokes to reduce handle force. Maximum leverage is obtained in the last 5 degrees of stroke.

6.2 Two Stage Flow

Under no loading, the pump operates in the high flow stage for fast advance. When the load is contacted, the pump shifts automatically to the low flow stage to build up pressure. After the pump shifts, priming takes less force.

Note: For the best performance, priming pump handle at moderate speed during the high flow stage. Fast handle speed in the high flow stage will prevent the pump from delivering full volume of oil.

6.3 Pump Operation – HP80

This model is equipped with a 3-way, 2-position control valve and designed for use with single-acting cylinders.

CAUTION: Never fill the reservoir unless the connected rams are fully retracted.

Max. Capacity : 700 Bar (10,000PSI)

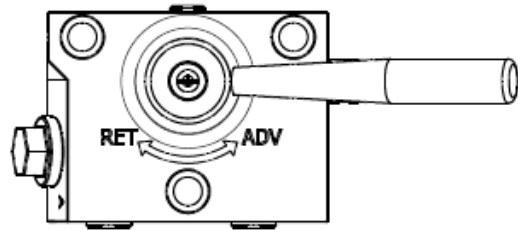

6.4 Pump Operation – HP80D

This model is equipped with a 4-way, 3-position control valve and designed for use with double-acting cylinder. Position lever on 4-way valve to select functions as follows.

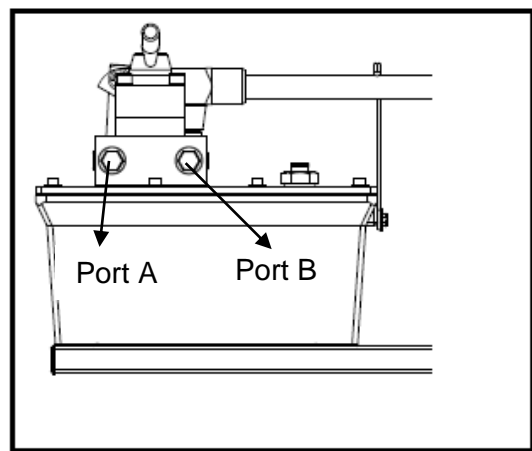
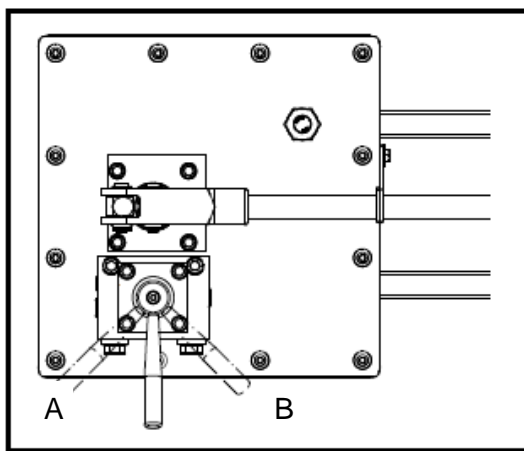

- (A) Flow directed to port “A”; Port “B” returns flow to the reservoir.
- (N) Neutral – Ports “A” and “B” open to the reservoir.
- (R) Flow directed to port “B”; port “A” returns flow to the reservoir.

Valve Function	Use with Cylinder Type
<div style="display: flex; justify-content: space-around;"> <div style="text-align: center;"> <p>POSITION "A"</p> </div> <div style="text-align: center;"> <p>CENTER POSITION</p> </div> <div style="text-align: center;"> <p>POSITION "B"</p> </div> </div>	Single & double acting
	Valve Type
	4-way, 3-position, pump mounted manual detent

Max. Capacity: 700 Bar (10,000 PSI)

⚠ CAUTION! Valve contains no load holding device. Be sure load is supported by blocking, mechanical stands or other appropriate supports before moving valve lever to the neutral (N) position.

7.0 AIR BLEEDING

Removing air from the hydraulic system will help the cylinder to advance and retract smoothly.

7.1 Pump W/ Single-Acting Cylinder

1. Loosen and remove oil fill plug to provide reservoir venting during the following steps.
2. Fully close release valve.
3. Position pump in the horizontal position at higher level than cylinder.
4. Position cylinder with the plunger end down (up if using pull cylinder).
5. Operate pump to extend the piston of cylinder fully (retract if using pull cylinder).
6. Open release valve to retract cylinder (extend if using pull cylinder). This will force the trapped air to move up to the pump reservoir.
7. Repeat steps 2 through 6 as needed, until cylinder operation is smooth.
8. Add oil if necessary, see Section 8.1
9. Assemble oil fill plug back.

7.2 Pump W/ Double-Acting Cylinder

1. Loosen oil plug several turns to allow reservoir venting during the follows.
2. Position pump in the horizontal position as higher level then cylinder.
3. Put cylinder in horizontal position with ports above.
4. Advance and retract the piston of cylinder 2 to 3 times fully.
5. Repeat steps 2 through 4 as needed, until cylinder operation is smooth.
6. Add oil if necessary. See Section 8.1
7. Assemble oil fill plug back.

8.0 MAINTENANCE

8.1 Adding Oil to the pump

IMPORTANT: Always add oil with cylinders fully retracted (extended if pull cylinders) or the system will contain more oil than the reservoir capacity.

Check oil level regularly and add oil if needed. Refer to the follows.

1. Place pump in the horizontal position on a level surface.
2. Remove oil fill plug from reservoir.
3. Check oil level. See Figure Right If oil level is low, add additional oil.

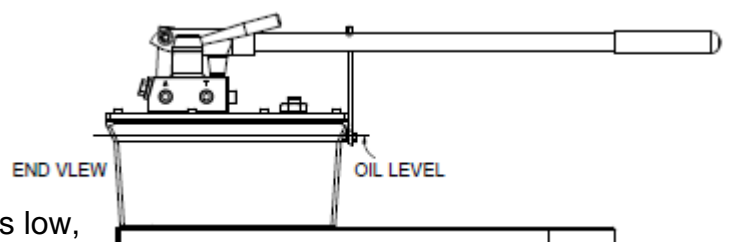

IMPORTANT: Do not overfill! Some air space must be present in reservoir to allow proper operation. If the reservoir contains too much oil, a vacuum will form, prevent oil flow when pump is operated.

4. Assemble oil fill plug back after oil added. Be sure the plug is fully tightened (not loose).

5. Remove air from system if necessary. See Section 7.0. Recheck oil level after air removed.

8.2 Lubrication

To extend pump life and improve performance, lubricate the handle pins regularly.

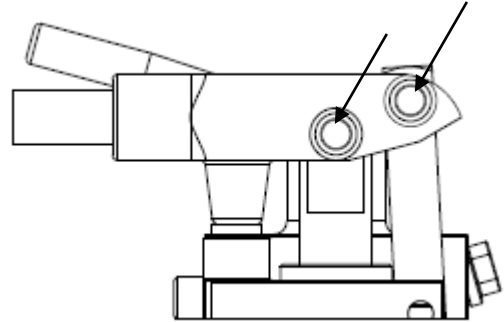

9.0 TROUBLESHOOTING GUIDE

A system failure may or may not be the result of a pump malfunction. To determine the cause of the problem is the key issue.

<u>PROBLEM</u>	<u>CAUSE</u>	<u>SOLUTION</u>
Cylinder does not advance, advances slowly or Advances difficultly	<ol style="list-style-type: none"> 1. System components leaking. 2. Lower fluid level in Reservoir. 3. Load is too heavy. 4. Air tapped into system. 5. Too much fluid in Reservoir. 6. Release valve not fully closed. 	<ol style="list-style-type: none"> 1. Check all connection are fully tightened. 2. Add oil. 3. Don't attempt to lift more than rated capacity. 4. Air bleeding per the instruction in Section 7.0. 5. Remove excess oil. 6. Close the release Valve fully.
Cylinder advances, but not holding pressure	<ol style="list-style-type: none"> 1. System components leaking. 2. Fluid leading past inlet or outlet checks. 3. Seals worn or leaking 	<ol style="list-style-type: none"> 1. Check all connection are fully tightened. 2. Contact with Authorized Dealers for service. 3. Contact with Authorized Dealers for service.
Pump handle has a "spongy" feel	<ol style="list-style-type: none"> 1. Air tapped into system. 	<ol style="list-style-type: none"> 1. Refer to Section 7.0 Air Bleeding.