

Quick action safety lock

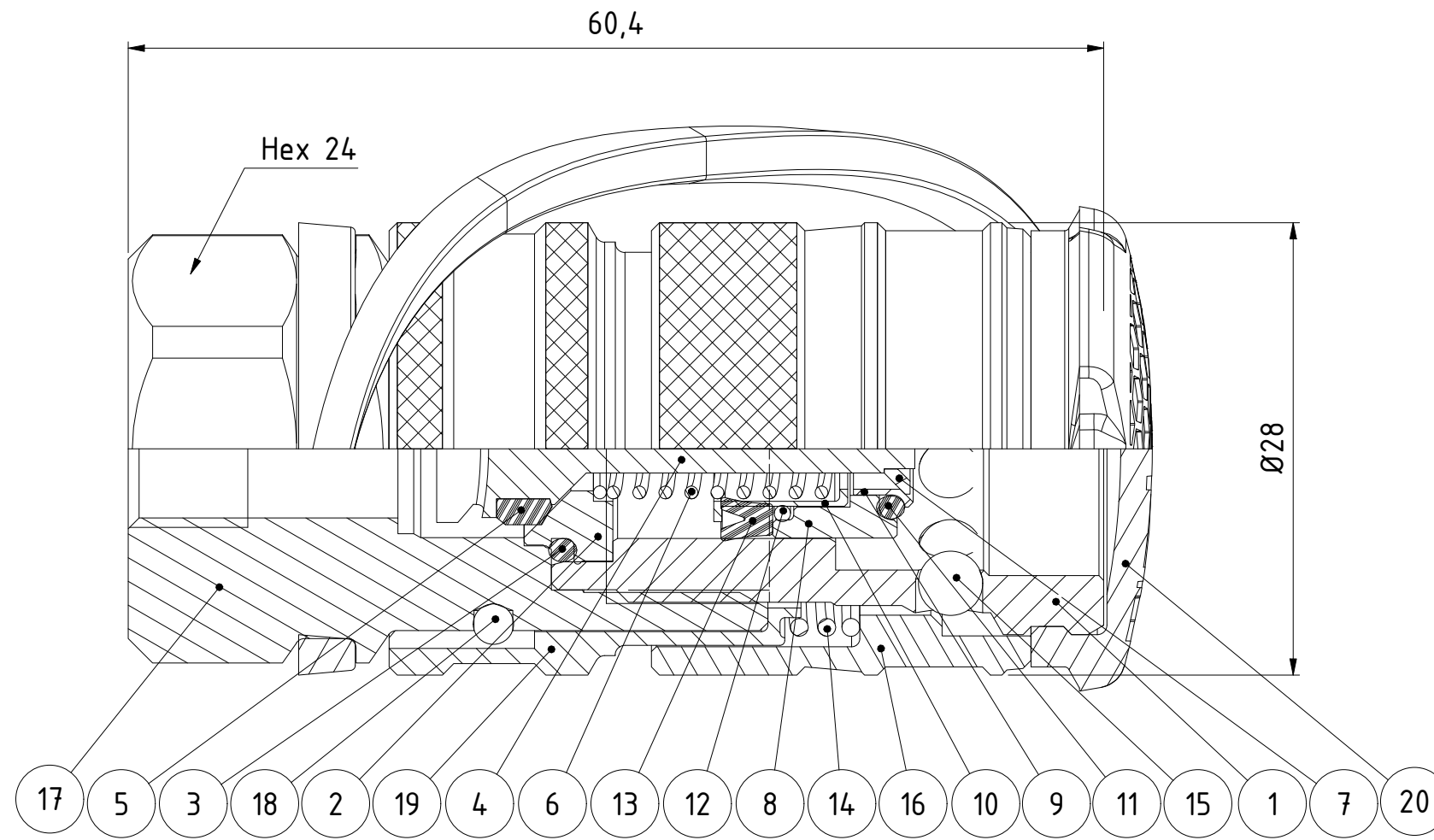

1 : 1



20	1	Dust Cap	TPE, black
19	1	Sleeve	Steel, Zn-Ni 10 black
18	2	Ball	Stainless steel
17	1	Back part	Steel, Zn 8 silver
16	1	Locking sleeve	Hard.steel, Zn-Ni 10 black
15	9	Ball	Stainless steel
14	1	Spring	Stainless steel
13	1	Lip seal	NBR
12	1	O-ring	NBR
11	1	O-ring	NBR
10	1	Spring housing	Steel
9	1	O-ring sleeve	Steel
8	1	Expansion sleeve	Plastic
7	1	Washer	Steel
6	1	Spring	Steel
5	1	Seal	NBR
4	1	Valve	Steel, FeZn5
3	1	O-ring	NBR
2	1	Valve seat	Steel
1	1	Front part	Steel, Zn 8 silver
Item	Qty	Description	Material

Product No.	101161201
Nominal flow \varnothing DN:	2.5 mm
Connection Stroke:	18.3 mm
Max WP Connected:	1500 bar
Max WP Disconnected:	1500 bar
Min BP Connected:	3000 bar
Min BP Disconnected:	3000 bar
Temperature range:	-30°C - +100°C
Connection:	G 1/8" Fem
Sealing material:	NBR
Hexagon:	24

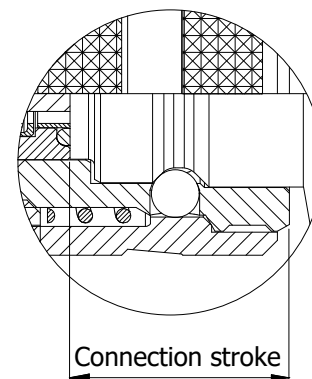

Connection stroke



Scale	5:2	Drawn	CABAO	Checked	FR	Appr.	JE	ECO	12061	Date	2018-04-18
Drawing No.								Issue		Sheet	
Assembly Drawing								501161201		AC 1/(1)	

This document must not be copied, either completely or in part, without permission. Any infringement will have legal consequences ©

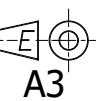

A3