

This document must not be copied, either completely or in part, without permission. Any infringement will have legal consequences ©

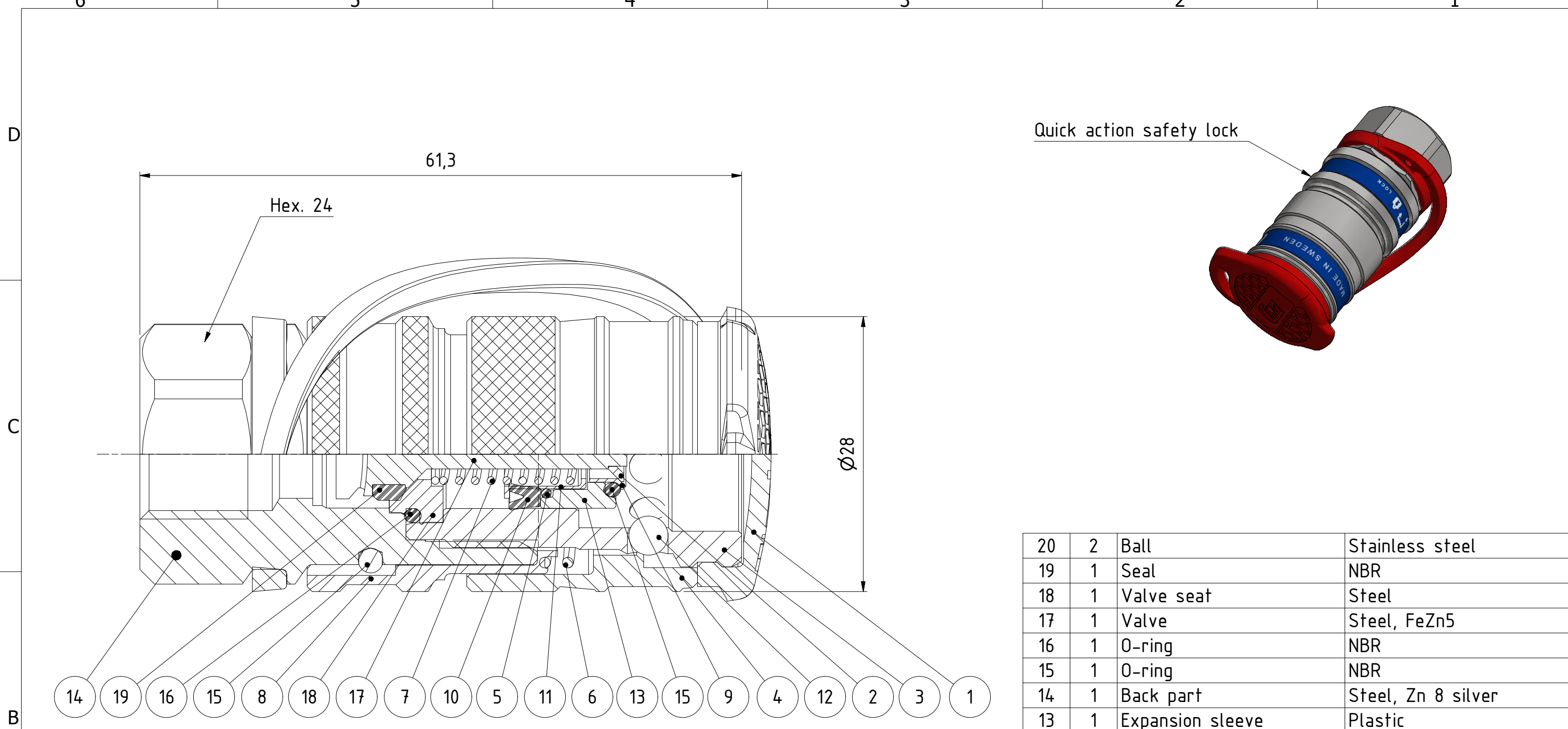

20	2	Ball	Stainless steel
19	1	Seal	NBR
18	1	Valve seat	Steel
17	1	Valve	Steel, FeZn5
16	1	O-ring	NBR
15	1	O-ring	NBR
14	1	Back part	Steel, Zn 8 silver
13	1	Expansion sleeve	Plastic
12	9	Ball	Stainless steel
11	1	Spring housing	Steel
10	1	Lip seal	NBR
9	1	O-ring sleeve	Steel
8	1	Sleeve	Steel, Zn 8 silver
7	1	Spring	Steel
6	1	Spring	Steel
5	1	O-ring	NBR
4	1	Locking sleeve	Hard. steel, Zn 8 Silver
3	1	Front part	Steel, Zn 8 silver
2	1	Washer	Steel
1	1	Dust Cap	TPE, red
Item	Qty	Description	Material

Product No. 101151202	
Nominal flow Ø DN:	2.5 mm
Connection Stroke:	18.3 mm
Max WP Connected:	1000 bar
Max WP Disconnected:	1000 bar
Min BP Connected:	2600 bar
Min BP Disconnected:	2600 bar
Temperature range:	-30°C - +100°C
Connection:	G1/4" female
Sealing material:	NBR
Hexagon:	24

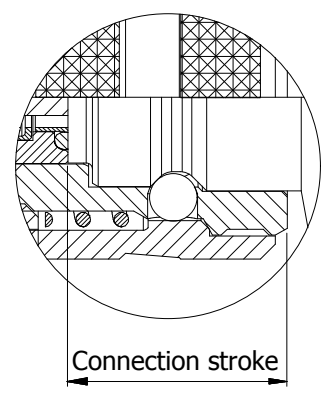

Scale: 2,5 : 1 Drawn: CABAO Checked: FR Appr.: JE ECO: 12061 Date: 2018-04-23

CEJN Drawing No. 501151202 Issue: AC Sheet: 1/(1)

A3