

SQ Series

OPERATION AND MAINTENANCE

MANUAL

SQ Series Uni-Swivel Square Drive
Hydraulic Torque Wrenches
MODELS SQ-1, SQ-3, SQ-5 & SQ-10



1025 Conroy Place, Easton, PA. 18040 U.S.A.

Phone: +1 610-250-5800
Fax: +1 610-250-2700
Toll Free: 1-888-TORCUP-1
Email: sales@torcup.com
Website: www.torcup.com



NOTICE

Series SQ-1, SQ-3, SQ-5 & SQ-10 SQ Series Uni-Swivel Square Drive Hydraulic Torque Wrenches are designed for installing and removing threaded fasteners requiring precise high torque during bolt makeup and maximum torque during bolt breakout.

TorcUP Inc. is not responsible for customer modification of tools for applications on which Torcup Inc. was not consulted.

WARNING

**IMPORTANT SAFETY INFORMATION ENCLOSED.
READ THIS MANUAL BEFORE OPERATING TOOL.**

**IT IS THE RESPONSIBILITY OF THE EMPLOYER TO PLACE THE INFORMATION IN THIS
MANUAL INTO THE HANDS OF THE OPERATOR.**

FAILURE TO OBSERVE THE FOLLOWING WARNINGS COULD RESULT IN INJURY.

USING THE TOOL

- Always operate, inspect and maintain this tool in accordance with American National Standards Safety Code for Hydraulic Rams and Jacks (ANSI B30.1).
- This tool will function using an air or electric powered hydraulic pump. Adhere to the pump safety requirements and follow instructions when connecting the pump to the tool.
- Use only equipment rated for the same pressure and torque.
- Use only a hydraulic pump capable of generating 10,000 psi (681 bar) maximum pressure with this tool.
- Use only twin line hydraulic hose rated for 10,000 psi (681 bar) pressure with this tool.
- Do not interchange the male and female swivel inlets on the tool or the connections on one end of the hose. Reversing the inlets will reverse the power stroke cycle and may damage the tool.
- Do not use damaged, frayed or deteriorated hoses and fittings. Make certain there are no cracks, splits or leaks in the hoses.
- Use the quick connect system to attach the hoses to the tool and pump.
- When connecting hoses that have not been preloaded with hydraulic oil, make certain the pump reservoir is not drained of oil during start-up.
- Do not remove any labels. Replace any damaged label.
- Do not handle pressurized hoses. Escaping oil under pressure can penetrate the skin, causing serious injury. If oil is injected under the skin, see a doctor immediately.
- Never pressurize uncoupled couplers. Only use hydraulic equipment in a coupled system.
- Always wear eye protection when operating or performing maintenance on this tool.
- Always wear head and hand protection and protective clothing when operating this tool.

The use of other than genuine Torcup replacement parts may result in safety hazards, decreased tool performance, increased maintenance, and may invalidate all warranties. Repairs should be made only by authorized personnel. Consult your nearest Torcup Authorized Service Center.

Refer All Communications to the Nearest Torcup Office or Distributor.

For Technical Support & Information Contact:

TorcUP Inc.

1025 Conroy Place, Easton, PA 18040 USA

Phone: +1 610-250-5800 Fax: +1 610-250-2700

email: sales@torcup.com

WARNING

FAILURE TO OBSERVE THE FOLLOWING WARNINGS COULD RESULT IN INJURY

Do NOT Exceed Maximum Pressure. See Torque Chart with Tool. Damage May Occur.

Do not use damaged, frayed or deteriorated hydraulic hoses and fittings.



Always wear eye protection when operating or performing maintenance on this tool.



Always wear ear protection when operating this tool.



Do not carry the tool by the hose.



Keep body stance balanced and firm. Do not overreach when operating this tool.



The Torque Reaction Arm must be positioned against a positive stop. Do not use the arm as a dead handle. Take all precautions to make certain the operator's hand cannot be pinched between the arm and a solid object.



USING THE TOOL

- Keep hands, loose clothing and long hair away from the reaction arm and working area during operation.
- This tool will exert a strong reaction force. Use proper mechanical support and correct reaction arm positioning to control these forces. Do not position the reaction arm so that it tilts the tool off the axis of the bolt and never use the swivel inlets as a reaction stop.
- Avoid sharp bends and kinks that will cause severe back-up pressure in hoses and lead to premature hose failure.
- Use accessories recommended by TorcUP.
- Use only impact sockets and accessories. Do not use hand (chrome) sockets or accessories.
- Use only sockets and accessories that correctly fit the bolt or nut and function without tilting the tool off the axis of the bolt.
- This tool is not insulated against electric shock.
- This equipment must not be operated or serviced unless the operator read the operating instructions and fully understands the purpose, consequences and procedure of each step.
- When operating a larger tool above waist height, employ a secondary means of support for safety purposes. A tool sling or chains may be used. Consult your safety department for further suggestions.

Depending on the working environment your local health and safety regulations may require you wear protective gear (i.e. safety shoes, hard hat, gloves, coveralls, etc.). In case external forces are exerted on the equipment, non-compliance with these regulations may result in injury. EAR PROTECTION MUST BE WORN WHEN OPERATING THIS TOOL.

PLACING THE TOOL IN SERVICE

CONNECTING THE TOOL

1. Attach the twin line hose to the swivel inlets of the square drive torque wrench using the spring-loaded quick connect ends.
2. Connect the opposite ends of the hose to the pump in the same manner.

ADJUSTMENTS

SETTING THE SQUARE DRIVE FOR ROTATION

The position of the square drive when looking toward the shroud will determine if the tool is set to tighten or loosen the nut. When the square drive extends to the left when looking at the shroud with the swivels away from you, the tool is set to loosen the nut. When the square drive extends to the right, the tool is set to tighten the nut. To change the direction of rotation for models SQ-1 SQ-3, and SQ-10 simply push the square drive into the housing until the drive projects out the opposite side of the tool. For the model SQ-5, loosen and remove the square drive retaining knob, and pull the square drive out of the housing. Insert the square drive into the opposite side of the housing, and secure it by installing the knob in the splined end of the drive.

SETTING THE TORQUE

After determining the desired torque, use the calibration certificate provided with the tool to determine the pressure necessary to achieve that torque. You may also refer to the chart engraved on the shroud of the tool or the chart provided on pages 8-11 of this manual.

1. Connect the tool to the power supply and turn the pump on.
2. Depress the remote control button causing the pressure to be shown on the gauge.
3. Adjust the pressure by loosening the wing nut that locks the pressure adjustment thumb screw. Rotate the thumbscrew clockwise to increase the pressure and counterclockwise to decrease the pressure. When decreasing pressure, always lower the pressure below the desired point and then bring the gauge back up to the desired pressure.
4. When the desired pressure is reached, retighten the wing nut and cycle the tool again to confirm that the desired pressure setting has been obtained.

SETTING THE REACTION ARM

The function of a reaction device is to hold the tool in position against the forces generated to tighten or loosen bolts or nuts. Hydraulic wrenches generate tremendous force.

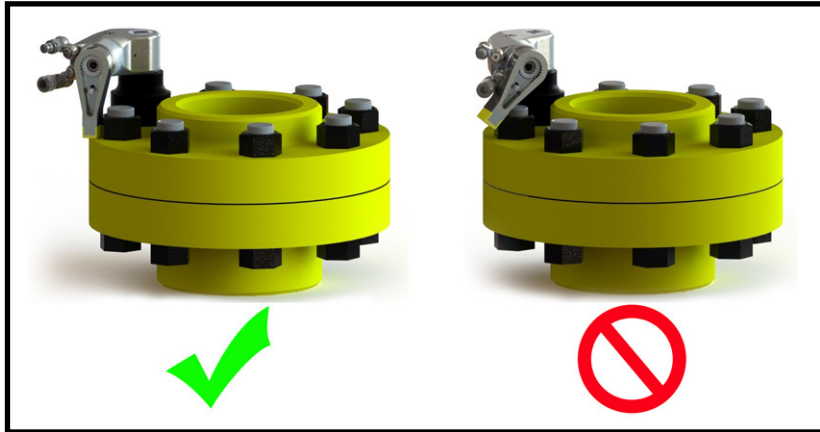

WARNING

An improperly positioned reaction arm may result in operator injury or damage to tooling.

Square Drive Hydraulic Wrench Reaction Points (Dwg.01)

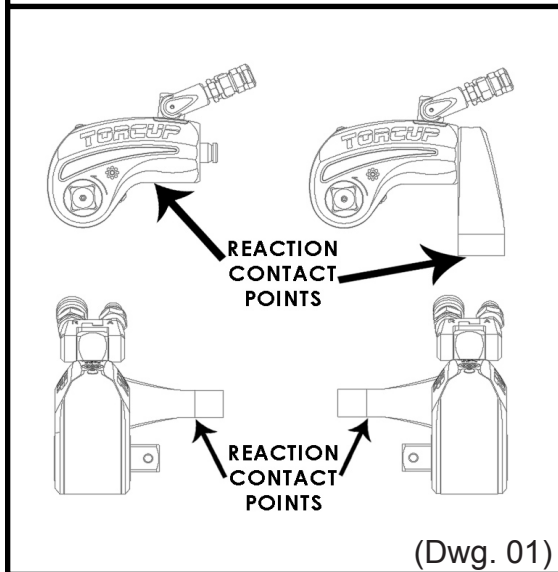

Make sure the reaction arm is positioned correctly. (Refer to Dwg. 01).

The reaction arm can be positioned numerous places within a 360° circle. However, for the arm to be correctly positioned, it must be set within a 90° quadrant of that circle. That quadrant is the area located between the protruding square drive and the bottom of the housing away from the swivel inlets. It will always be toward the lower half of the housing and on one side of the housing when tightening and on the other side when loosening.

OPERATING THE WRENCH

Square Drive Position for Loosening and Tightening(Dwg.02)

The position of the square drive relative to the shroud determines whether the action will tighten or loosen the nut. (Refer to Dwg. 02 for application examples). The power stroke of the piston assembly will always turn the square drive toward the shroud.

1. Insert the square drive into the mating socket. Then, insert the safety pin through the socket, and seat the included O-ring into the groove to capture the pin. Place the socket onto the nut making sure the socket is the proper size and that all mating parts are fully seated.
2. Position the reaction arm or surface against an adjacent nut, flange or solid system component. Make certain that there is clearance for the hoses, swivels, inlets and end plug. DO NOT allow the tool to react against the hoses, swivels, inlets or end plug.
3. After turning the pump on and presetting the pressure for the correct torque, depress the remote control button to advance the piston assembly.
4. When the wrench is started, the reaction surface of the wrench or reaction arm will move against the contact point, and the nut will begin to turn.
5. When the nut is no longer turning and the pump gauge reaches the preset pressure, release the remote control button. The piston rod will retract when the button is released, and under normal conditions, an audible “click” will be heard as the tool resets itself.
6. Continue to cycle the tool until it “stalls” and the preset psi/torque has been attained.
7. Cycle the tool one additional time to ensure full torque.

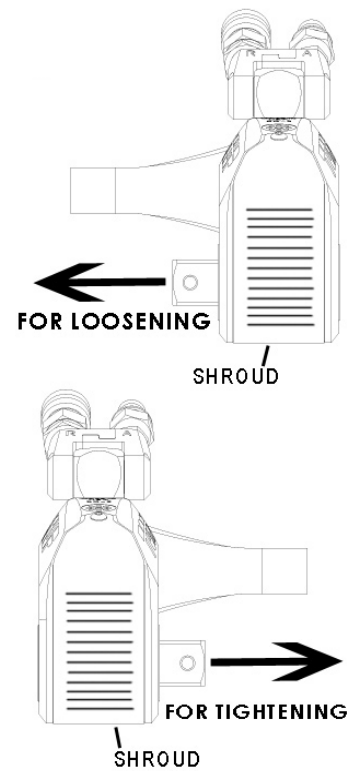

Drawing 02

LUBRICATION

MARINE MOLY GREASE

Lubrication frequency is dependent on factors known only to the user. The amount of contaminants in the work area is one factor. Tools used in a clean room environment will obviously require less service than a tool used outdoors and dropped in loose dirt or sand. Marine Moly Grease is formulated not to wash out of the tool in areas where lubrication is critical.

Whenever lubrication is required, lubricate as follows:

1. Remove the drive plate, ratchet, drive segment and sleeves as instructed in the maintenance section, and wash the components in a suitable cleaning solution in a well ventilated area.
2. After drying the components, wipe a film of Marine Moly Grease onto the wear surface of both sleeves and the ends of the ratchet.
3. Spread a light film of Marine Moly Grease onto the inner face and both sides of the drive plate. **Do not pack** the teeth of the drive segment or ratchet with lubricant. It can prevent the teeth from engaging properly.
4. Place a daub of Marine Moly Grease in the piston rod recess of the drive plate before linking the piston rod to the drive plate at assembly.

CRITICAL LUBRICATION

It is imperative to lubricate the piston rod recess of the drive plate to piston rod contact area every 80 hours of continuous duty cycling.

Lubricate as follows:

1. Remove shroud screws, shroud, and roll pin.
2. Pry the drive plate assembly forward from the piston rod to expose the recessed contact area in the drive plate.
3. With a rag, wipe clean the area, and apply a sizeable amount of Marine Moly Grease.
4. Reassemble as instructed in the maintenance section.

SQ Series Uni-Swivel Wrench Technical & Dimensional Data

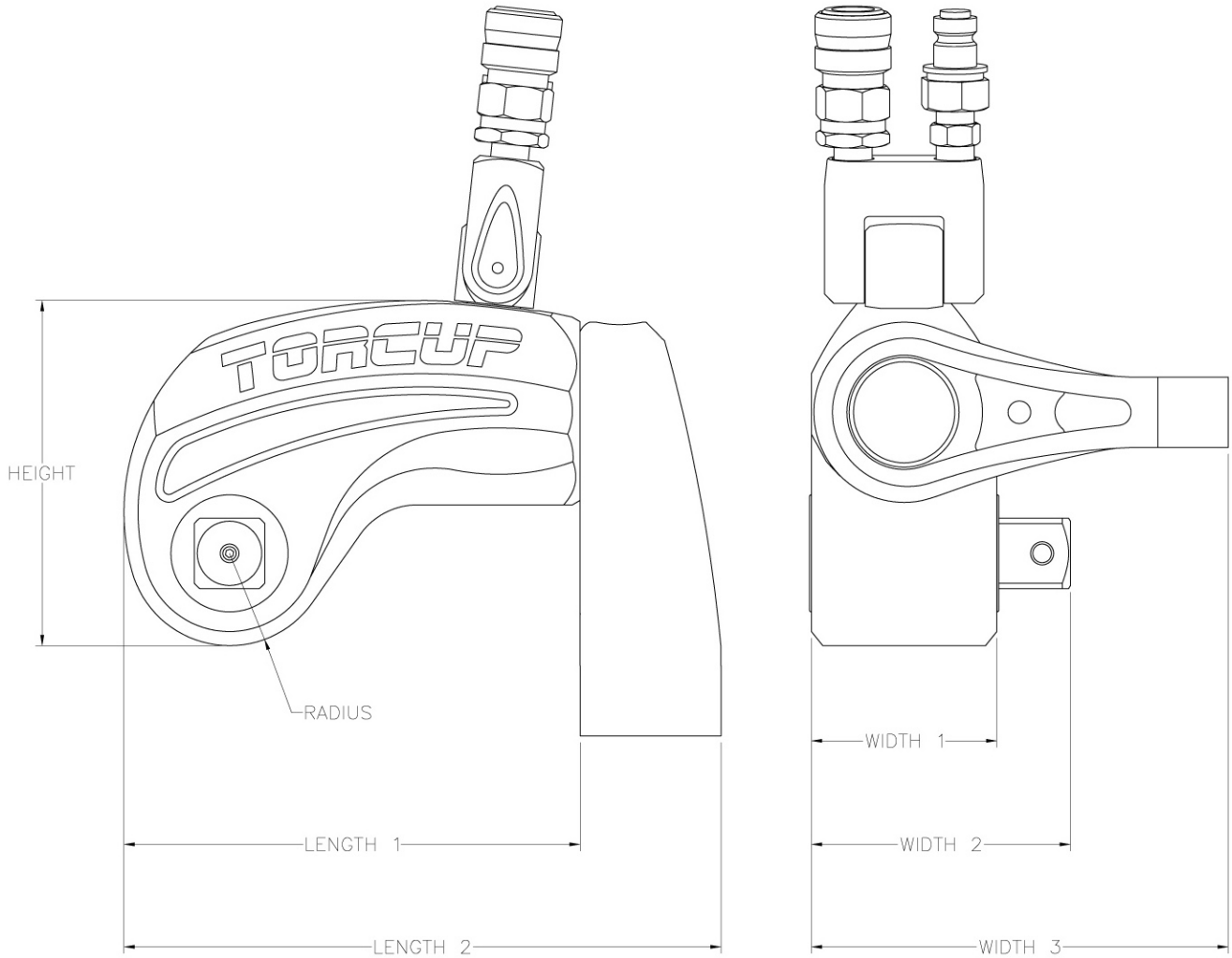

Model Number	SQ-1	SQ-3	SQ-5	SQ-10
Square drive	3/4"	1"	1 1/2"	1 1/2"
Min. Torque (ft/lbs)	132	292	587	1198
Max. Torque (ft/lbs)	1345	3425	5922	11908
Min. Torque (nm)	179	396	796	1624
Max. Torque (nm)	1824	4644	8029	16145
Output Accuracy	+/-3%	+/-3%	+/-3%	+/-3%
Repeatability	100%	100%	100%	100%
Duty Cycle	100%	100%	100%	100%
Tool Weight (lbs/kg)	5.5/2.5	11.0/5.0	18.5/8.4	32.0/14.5
Height (in/mm)	3.76/95.5	4.91/124.7	6.05/153.6	7.34/186.4
Length 1 (in/mm)	4.91/124.7	6.48/164.5	7.95/201.9	9.85/250.1
Length 2 (in/mm)	6.47/164.3	8.48/215.3	10.70/271.7	2.85/326.3
Radius (in/mm)	0.99/25.1	1.31/33.2	1.57/39.8	2.13/54.1
Width 1 (in/mm)	2.00/50.8	2.63/66.8	3.13/79.5	3.95/100.3
Width 2 (in/mm)	2.75/69.8	3.68/93.5	4.64/117.8	5.47/138.9
Width 3 (in/mm)	4.61/117.0	5.92/150.3	7.00/117.8	8.74/222.0



TORCUP

2016 - March

SQ-1 Torque Conversion Chart

Imperial Conversion		Metric Conversion	
PSI	Ft-lbs	Bar	Nm
1,000	132	69	179
1,200	159	83	216
1,400	185	97	251
1,600	212	110	287
1,800	238	124	323
2,000	265	138	359
2,200	292	152	396
2,400	319	165	433
2,600	346	179	469
2,800	373	193	506
3,000	400	207	542
3,200	427	221	579
3,400	454	234	616
3,600	481	248	652
3,800	508	262	689
4,000	535	276	725
4,200	561	290	761
4,400	588	303	797
4,600	614	317	832
4,800	641	331	869
5,000	667	345	904
5,200	694	359	941
5,400	721	372	978
5,600	747	386	1013
5,800	774	400	1049
6,000	801	414	1086
6,200	828	427	1123
6,400	855	441	1159
6,600	883	455	1197
6,800	910	469	1234
7,000	937	483	1270
7,200	964	496	1307
7,400	990	510	1342
7,600	1017	524	1379
7,800	1043	538	1414
8,000	1070	552	1451
8,200	1098	565	1489
8,400	1126	579	1527
8,600	1153	593	1563
8,800	1181	607	1601
9,000	1209	621	1639
9,200	1236	634	1676
9,400	1263	648	1712
9,600	1291	662	1750
9,800	1318	676	1787
10,000	1345	689	1824

For reference purposes only, please consult the calibration chart specific to your purchase or rental tool.



TORCUP

2016 - March

SQ-3 Torque Conversion Chart

Imperial Conversion		Metric Conversion	
PSI	Ft-lbs	Bar	Nm
1,000	292	69	396
1,200	359	83	487
1,400	425	97	576
1,600	492	110	667
1,800	558	124	757
2,000	625	138	847
2,200	693	152	940
2,400	761	165	1032
2,600	830	179	1125
2,800	898	193	1218
3,000	966	207	1310
3,200	1036	221	1405
3,400	1105	234	1498
3,600	1175	248	1593
3,800	1244	262	1687
4,000	1314	276	1782
4,200	1384	290	1876
4,400	1453	303	1970
4,600	1523	317	2065
4,800	1592	331	2158
5,000	1662	345	2253
5,200	1734	359	2351
5,400	1807	372	2450
5,600	1879	386	2548
5,800	1952	400	2647
6,000	2024	414	2744
6,200	2096	427	2842
6,400	2169	441	2941
6,600	2241	455	3038
6,800	2314	469	3137
7,000	2386	483	3235
7,200	2457	496	3331
7,400	2527	510	3426
7,600	2598	524	3522
7,800	2668	538	3617
8,000	2739	552	3714
8,200	2809	565	3808
8,400	2878	579	3902
8,600	2948	593	3997
8,800	3017	607	4091
9,000	3087	621	4185
9,200	3155	634	4278
9,400	3222	648	4368
9,600	3290	662	4461
9,800	3357	676	4551
10,000	3425	689	4644

For reference purposes only, please consult the calibration chart specific to your purchase or rental tool.



TORCUP

2016 - March

SQ-5 Torque Conversion Chart

Imperial Conversion		Metric Conversion	
PSI	Ft-lbs	Bar	Nm
1,000	587	69	796
1,200	705	83	956
1,400	823	97	1116
1,600	940	110	1274
1,800	1058	124	1434
2,000	1176	138	1594
2,200	1294	152	1754
2,400	1413	165	1916
2,600	1531	179	2076
2,800	1650	193	2237
3,000	1768	207	2397
3,200	1885	221	2556
3,400	2002	234	2714
3,600	2120	248	2874
3,800	2237	262	3033
4,000	2354	276	3192
4,200	2474	290	3354
4,400	2595	303	3518
4,600	2715	317	3681
4,800	2836	331	3845
5,000	2956	345	4008
5,200	3076	359	4170
5,400	3196	372	4333
5,600	3315	386	4495
5,800	3435	400	4657
6,000	3555	414	4820
6,200	3673	427	4980
6,400	3791	441	5140
6,600	3909	455	5300
6,800	4027	469	5460
7,000	4145	483	5620
7,200	4265	496	5783
7,400	4386	510	5947
7,600	4506	524	6109
7,800	4627	538	6273
8,000	4747	552	6436
8,200	4864	565	6595
8,400	4982	579	6755
8,600	5099	593	6913
8,800	5217	607	7073
9,000	5334	621	7232
9,200	5452	634	7392
9,400	5569	648	7551
9,600	5687	662	7711
9,800	5804	676	7869
10,000	5922	689	8029

For reference purposes only, please consult the calibration chart specific to your purchase or rental tool.



TORCUP

2016 - March

SQ-10 Torque Conversion Chart

Imperial Conversion		Metric Conversion	
PSI	Ft-lbs	Bar	Nm
1,000	1198	69	1624
1,200	1433	83	1943
1,400	1668	97	2262
1,600	1904	110	2581
1,800	2139	124	2900
2,000	2374	138	3219
2,200	2612	152	3541
2,400	2850	165	3864
2,600	3088	179	4187
2,800	3326	193	4509
3,000	3564	207	4832
3,200	3802	221	5155
3,400	4041	234	5479
3,600	4279	248	5802
3,800	4518	262	6125
4,000	4756	276	6448
4,200	4990	290	6766
4,400	5225	303	7084
4,600	5459	317	7402
4,800	5694	331	7719
5,000	5928	345	8037
5,200	6164	359	8357
5,400	6400	372	8677
5,600	6635	386	8996
5,800	6871	400	9316
6,000	7107	414	9636
6,200	7348	427	9963
6,400	7589	441	10290
6,600	7831	455	10617
6,800	8072	469	10944
7,000	8313	483	11271
7,200	8547	496	11588
7,400	8781	510	11905
7,600	9015	524	12223
7,800	9249	538	12540
8,000	9483	552	12857
8,200	9727	565	13188
8,400	9971	579	13518
8,600	10214	593	13849
8,800	10458	607	14179
9,000	10702	621	14510
9,200	10943	634	14837
9,400	11184	648	15164
9,600	11426	662	15491
9,800	11667	676	15818
10,000	11908	689	16145

For reference purposes only, please consult the calibration chart specific to your purchase or rental tool.

SQ-1 Series Wrench

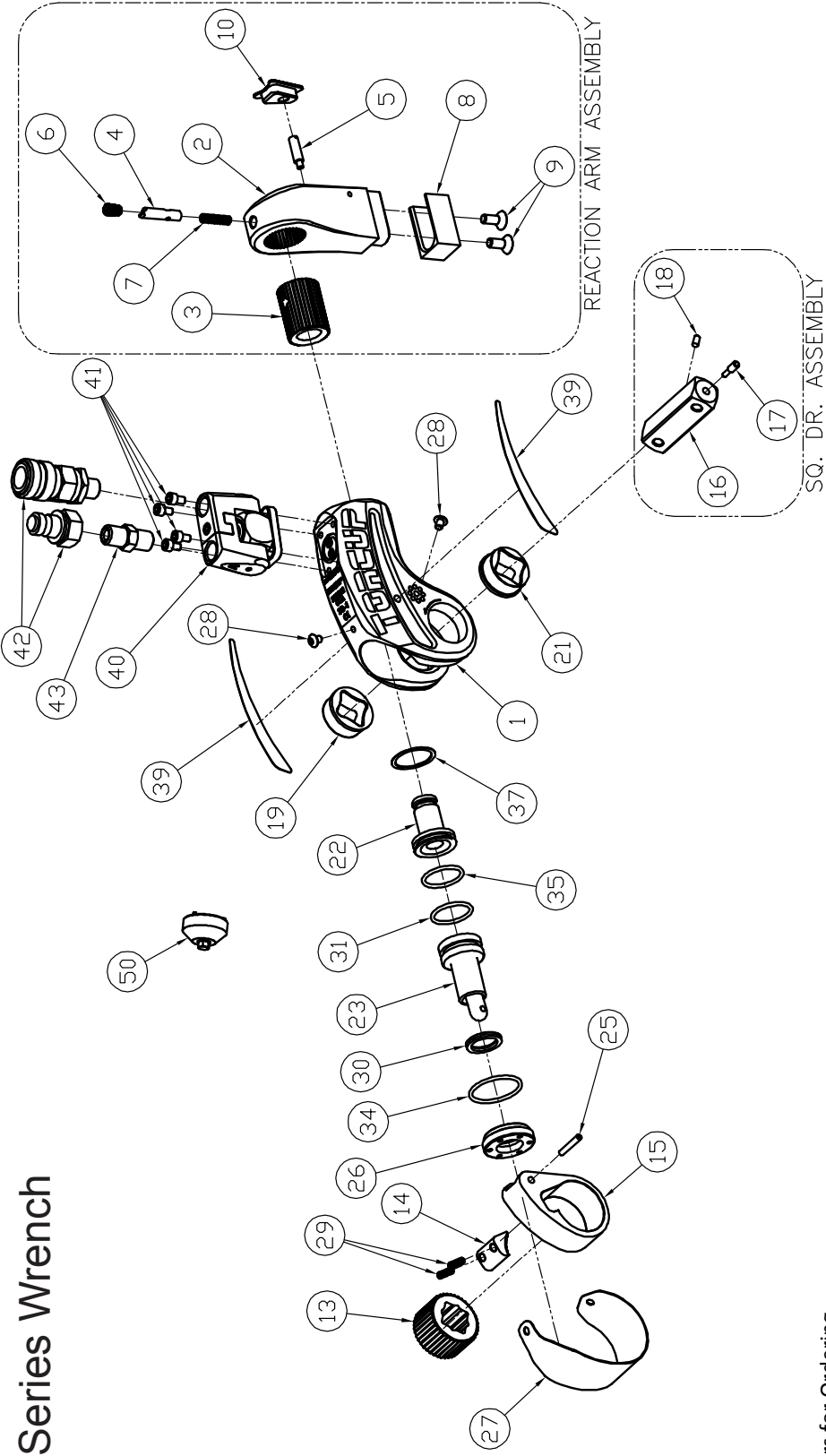

Part Numbers for Ordering

ITEM	NAME	PART #	QTY.	ITEM	NAME	PART #	QTY.	ITEM	NAME	PART #	QTY.
1	Housing	SQ-1-01	1	16	Square Drive	SQ-1-11-1	1	34	Gland Seal	SQ-1-35	1
2	Reaction Arm	SQ-1-03-1	1	17	Sq. Dr. Locking Pin	SQ-1-11-2	1	35	End Plug Seal	SQ-1-37	1
3	Spline Sleeve	SQ-1-03-2	1	18	Sq. Drive Pin	SQ-1-11-3	1	37	Cylinder Ring	SQ-1-43	1
4	Locking Pin	SQ-1-03-3	1	21	Sq. Drive Sleeve	SQ-1-13	2	39	Side Label Set	LBL-SQ-1	1
5	Retract Button	SQ-1-03-4	1	22	End Plug	SQ-1-15	1	40	Swivel Assembly	CSS-00	1
6	Reaction Arm Screw	SQ-1-03-5	1	23	Piston Rod Assembly	SQ-1-17-00	1	41	Swivel Post Screw	CSS-21	4
7	Retract Arm Spring	SQ-1-03-6	1	25	Roll Pin	SQ-1-19	1	42	Male Coupler	HC-M-100	1
8	Retract Arm Cover	SQ-1-03-7	1	26	Cylinder Gland	SQ-1-21	1	43	Female Coupler	HC-F-400	1
9	Cover Screw	SQ-1-03-8	2	27	Shroud	SQ-1-23	1	44	Male 1/4" NPT Nipple	F004004	1
10	Retract Button Cover	SQ-1-03-9	1	28	Shroud Screw	SQ-1-25	2	50	Gland Wrench	ATU-2-GW	1
13	Ratchet	SQ-1-05	1	29	Drive Segment Spring	SQ-1-27	2				
14	Drive Segment	SQ-1-07	1	30	Rod Seal	SQ-1-31	1		Reaction Arm Assembly	SQ-1-03	
15	Drive Plate	SQ-1-09	1	31	Piston Seal	SQ-1-33	1		Square Drive Assembly	SQ-1-11	

SQ-3 Series Wrench

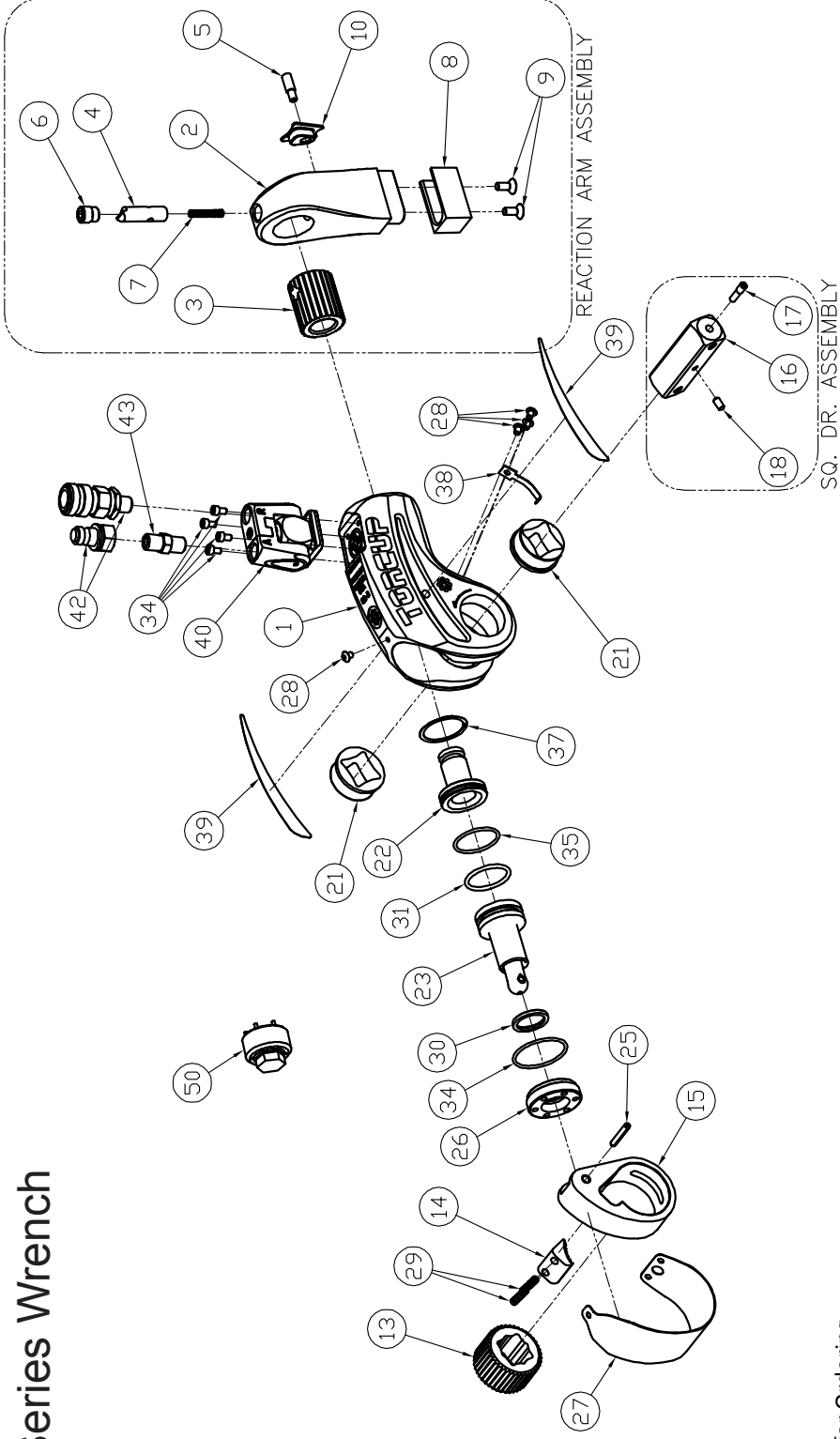

Part Numbers for Ordering

ITEM #	ITEM NAME	PART #	QTY.	ITEM NAME	PART #	QTY.	ITEM NAME	PART #	QTY.		
1	Housing	SQ-3-01	1	16	Square Drive	SQ-3-11-1	1	34	Gland Seal	SQ-3-35	1
2	Reaction Arm	SQ-3-03-1	1	17	Sq. Dr. Locking Pin	SQ-3-11-2	1	35	End Plug Seal	SQ-3-37	1
3	Spline Sleeve	SQ-3-03-2	1	18	Sq. Drive Pin	SQ-3-11-3	1	37	Cylinder Ring	SQ-3-43	1
4	Locking Pin	SQ-3-03-3	1	21	Sq. Drive Sleeve	SQ-3-13	2	38	Ratchet Spring	SQ-3-53	1
5	Retract Button	SQ-3-03-4	1	22	End Plug	SQ-3-15	1	39	Side Label Set	LBL-SQ-3	1
6	Reaction Arm Screw	SQ-3-03-5	1	23	Piston Rod Assembly	SQ-3-17-00	1	40	Swivel Assembly	CSL-00-3	1
7	Retract Arm Spring	SQ-3-03-6	1	25	Roll Pin	SQ-3-19	1	41	Swivel Post Screw	CSL-23	4
8	Retract Arm Cover	SQ-3-03-7	1	26	Cylinder Gland	SQ-3-21	1	42	Male Coupler	HC-M-100	1
9	Cover Screw	SQ-3-03-8	2	27	Shroud	SQ-3-23	1	43	Female Coupler	HC-F-400	1
10	Retract Button Cover	SQ-3-03-9	1	28	Shroud Screw	SQ-3-25	4	44	Male 1/4" NPT Nipple	F004004	1
13	Ratchet	SQ-3-05	1	29	Drive Segment Spring	SQ-3-27	2	50	Gland Wrench	ATU-3-GW	1
14	Drive Segment	SQ-3-07	1	30	Rod Seal	SQ-3-31	1				
15	Drive Plate	SQ-3-09	1	31	Piston Seal	SQ-3-33	1				

SQ-5 Series Wrench

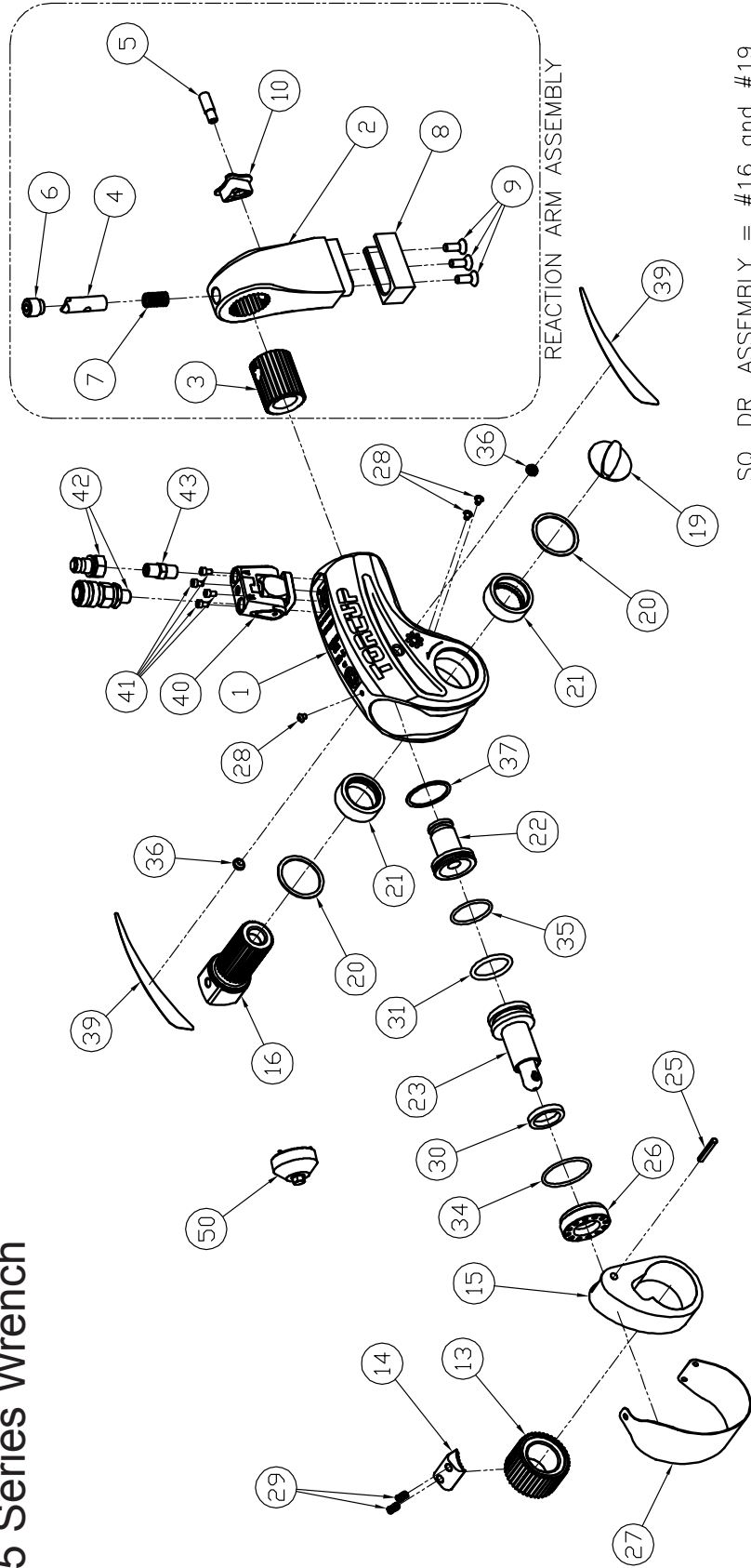

SQ. DR. ASSEMBLY = #16 and #19

Part Numbers for Ordering				
ITEM	NAME	PART #	QTY.	
1	Housing	SQ-5-01	1	
2	Reaction Arm	SQ-5-03-1	1	
3	Spline Sleeve	SQ-5-03-2	1	
4	Locking Pin	SQ-5-03-3	1	
5	Retract Button	SQ-5-03-4	1	
6	Reaction Arm Screw	SQ-5-03-5	1	
7	Retract Arm Spring	SQ-5-03-6	1	
8	Retract Arm Cover	SQ-5-03-7	1	
9	Cover Screw	SQ-5-03-8	3	
10	Retract Button Cover	SQ-5-03-9	1	
13	Ratchet	SQ-5-05	1	
14	Drive Segment	SQ-5-07	1	
15	Drive Plate	SQ-5-09	1	
16	Square Drive	SQ-5-11-1	1	
19	Sq. Dr. Retaining Knob	SQ-5-11-6	1	
20	Sleeve Retaining Ring	SQ-5-12	2	
21	Sq. Drive Sleeve	SQ-5-13	2	
22	End Plug	SQ-5-15	1	
23	Piston Rod Assembly	SQ-5-17-00	1	
25	Roll Pin	SQ-5-19	1	
26	Cylinder Gland	SQ-5-21	1	
27	Shroud	SQ-5-23	1	
28	Shroud Screw	SQ-5-25	3	
29	Drive Segment Spring	SQ-5-27	2	
30	Rod Seal	SQ-5-31	1	
31	Piston Seal	SQ-5-33	1	
34	Gland Seal	SQ-5-35	1	
35	End Plug Seal	SQ-5-37	1	
36	Housing Side Plug	SQ-5-39	2	
37	Cylinder Ring	SQ-5-43	1	
39	Side Label Set	LBL-SQ-5	1	
40	Swivel Assembly	CSL-00-5	1	
41	Swivel Post Screw	CSL-23	4	
42	Coupler Set	HC-S-100	1	
43	Male 1/4" NPT Nipple	F004004	1	
50	Gland Wrench	ATU-5-GW	1	
	Reaction Arm Assembly	SQ-5-03		
	Square Drive Assembly	SQ-5-11		

SQ-10 Series Wrench

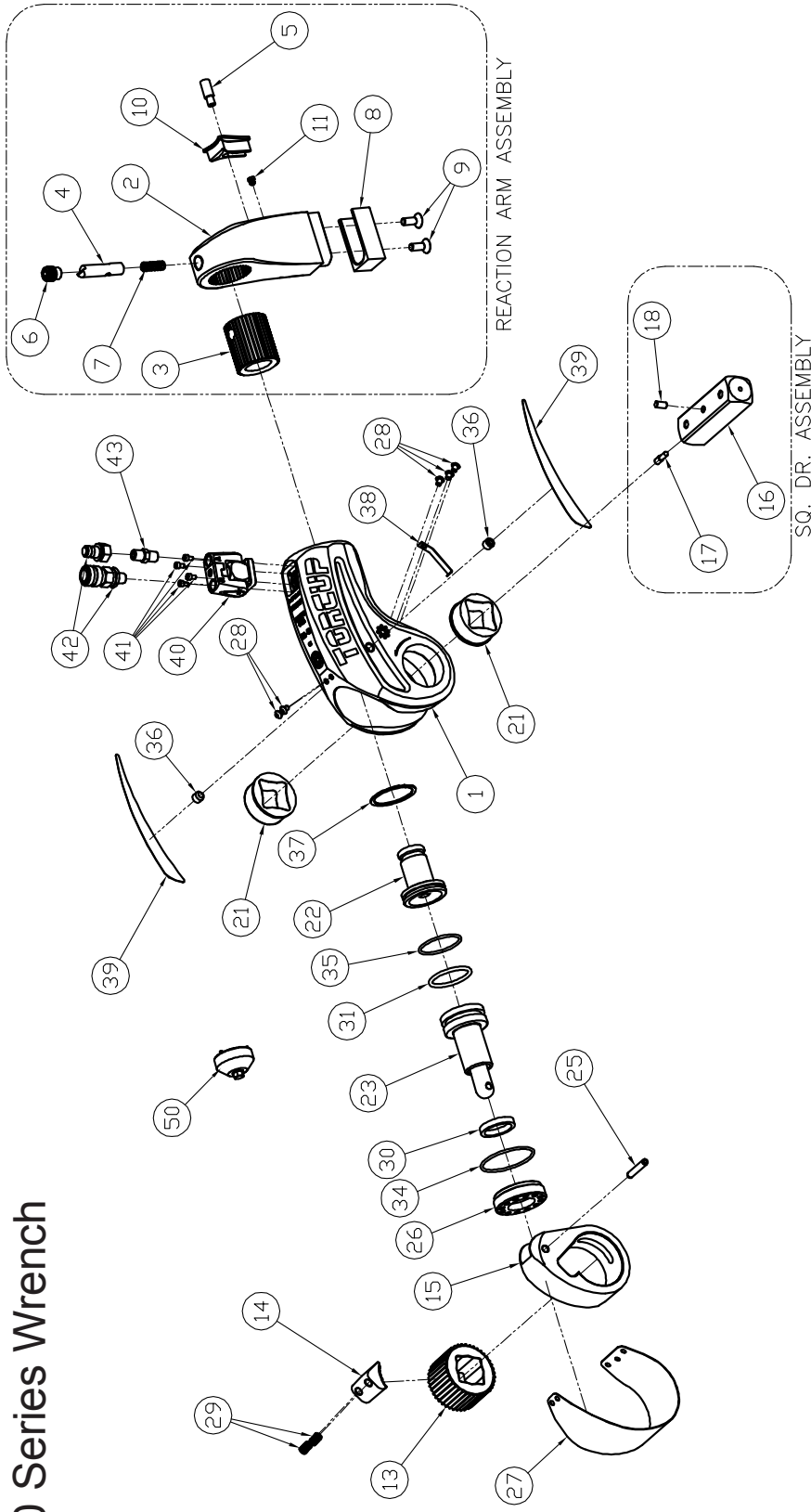

Part Numbers for Ordering

ITEM NAME	PART #	QTY.	ITEM NAME	PART #	QTY.
1 Housing	SQ-10-01	1	35 End Plug Seal	SQ-10-37	1
2 Reaction Arm	SQ-10-03-1	1	36 Side Housing Plugs	SQ-10-39	2
3 Spline Sleeve	SQ-10-03-2	1	37 Cylinder Ring	SQ-10-43	1
4 Locking Pin	SQ-10-03-3	1	38 Ratchet Spring	SQ-10-53	1
5 Retract Button	SQ-10-03-4	1	39 Side Label Set	LBL-SQ-10	1
6 Reaction Arm Screw	SQ-10-03-5	1	40 Swivel Assembly	CSL-00-5	1
7 Retract Arm Spring	SQ-10-03-6	1	41 Swivel Post Screw	CSL-23	4
8 Retract Arm Cover	SQ-10-03-7	1	42 Male Coupler	HC-M-100	1
9 Cover Screw	SQ-10-03-8	2	43 Female Coupler	HC-F-400	1
10 Retract Button Cover	SQ-10-03-9	1	44 Male 1/4" NPT Nipple	F004004	1
11 Ret. Button Guide Screw	SQ-10-03-10	1	45 Gland Wrench	ATU-11-GW	1
13 Ratchet	SQ-10-05	1			
14 Drive Segment	SQ-10-07	1			
15 Drive Plate	SQ-10-09	1			
16 Square Drive	SQ-10-11-1	1			
17 Sq. Dr. Locking Pin	SQ-10-11-2	1			
18 Sq. Drive Pin	SQ-10-11-3	1			
19 Sq. Drive Sleeve	SQ-10-13	2			
20 End Plug	SQ-10-15	1			
21 Piston Rod Assembly	SQ-10-17-00	1			
22 Roll Pin	SQ-10-19	1			
23 Cylinder Gland	SQ-10-21	1			
24 Shroud	SQ-10-23	1			
25 Shroud Screw	SQ-10-25	4			
26 Drive Segment Spring	SQ-10-27	2			
27 Rod Seal	SQ-10-31	1			
28 Piston Seal	SQ-10-33	1			
29 Gland Seal	SQ-10-35	1			
			Reaction Arm Assembly	SQ-10-03	
			Square Drive Assembly	SQ-10-11	

SQ Series CSS Uni-Swivel

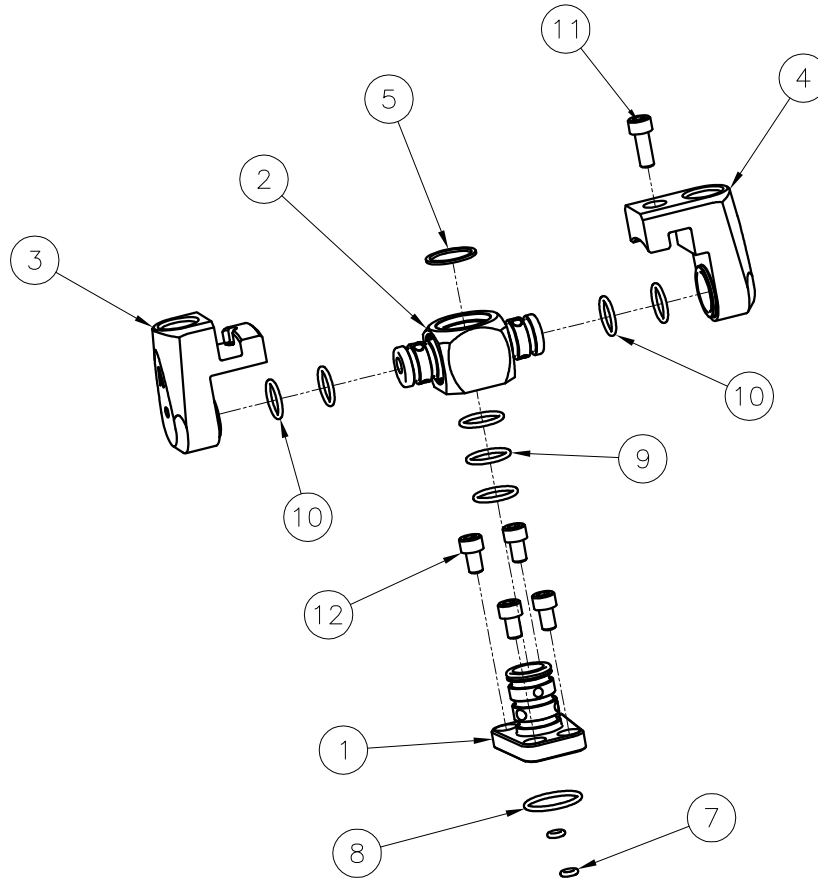

CSS Uni-Swivel Parts List

ITEM	NAME	PART #
1	Post	CSS-01
2	Joint	CSS-03
3	Swivel Arm (Advance)	CSS-05
4	Swivel Arm (Retract)	CSS-07
5	Retaining Ring	CSS-19
7	Swivel O-ring (Small)	CSS-09
8	Swivel O-ring (Large)	CSS-11
9	Post O-ring	CSS-13
10	Joint O-ring	CSS-15
11	Swivel Screw	CSS-17
12	Swivel Post Screw	CSS-21

Available Repair Kits

Post Kit CSS-PKIT

ITEM	NAME	PART #
1	Post	CSS-01
7	Swivel O-ring (Small)	CSS-09
8	Swivel O-ring (Large)	CSS-11
9	Post O-ring	CSS-13
12	Swivel Post Screw	CSS-21

Joint Kit CSS-JKIT

ITEM	NAME	PART #
2	Joint	CSS-03
3	Swivel Arm (Advance)	CSS-05
4	Swivel Arm (Retract)	CSS-07
5	Retaining Ring	CSS-19
9	Post O-ring	CSS-13
10	Joint O-ring	CSS-15
11	Swivel Screw	CSS-17

Seal Kit CSS-SKIT

ITEM	NAME	PART #
7	Swivel O-ring (Small)	CSS-09
8	Swivel O-ring (Large)	CSS-11
9	Post O-ring	CSS-13
10	Joint O-ring	CSS-15
12	Swivel Post Screw	CSS-21

SQ Series CSL Uni-Swivel

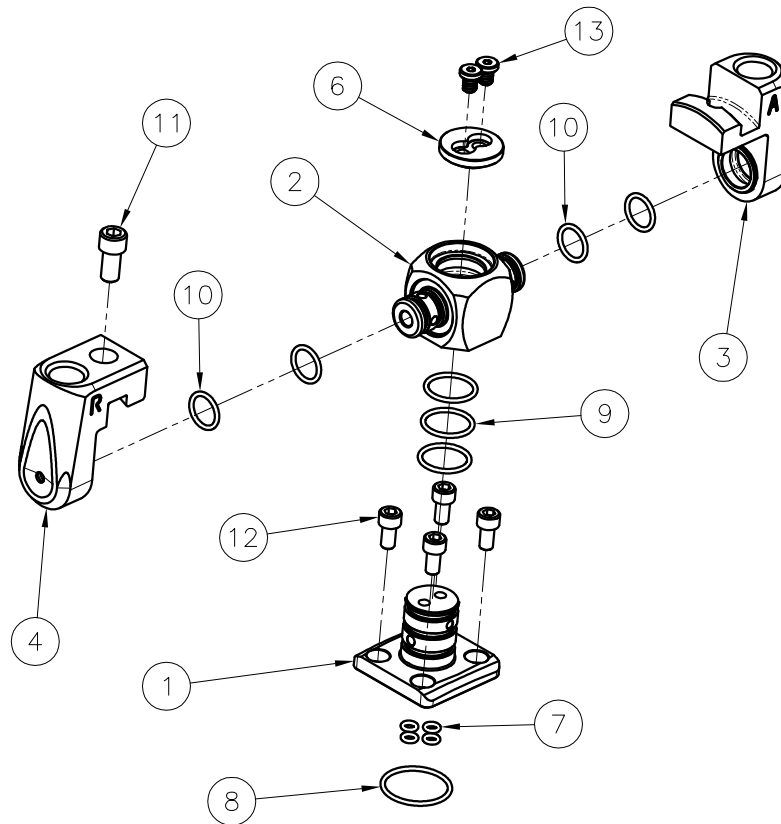

CSL Uni-Swivel Parts List

ITEM	NAME	PART #
1	Post	CSL-01-X*
2	Joint	CSL-03
3	Swivel Arm (Advance)	CSL-05
4	Swivel Arm (Retract)	CSL-07
6	Cap	CSL-09
7	Swivel O-ring (Small)	CSL-11
8	Swivel O-ring (Large)	CSL-13
9	Post O-ring	CSL-15
10	Joint O-ring	CSL-17
11	Swivel Screw	CSL-19
12	Swivel Post Screw	CSL-23
13	Cap Screw	CSL-21

Note: The SQ-3 uses post # CSL-01-3
The SQ-5 & 10 use post # CSL-01-5

Available Repair Kits

Post Kit CSL-PKIT

ITEM	NAME	PART #
1	Post	CSL-01-X*
7	Swivel O-ring (Small)	CSL-11
8	Swivel O-ring (Large)	CSL-13
9	Post O-ring	CSL-15
12	Swivel Post Screw	CSL-23

Joint Kit CSL-JKIT

ITEM	NAME	PART #
2	Joint	CSL-03
3	Swivel Arm (Advance)	CSL-05
4	Swivel Arm (Retract)	CSL-07
6	Cap	CSL-09
9	Post O-ring	CSL-15
10	Joint O-ring	CSL-17
11	Swivel Screw	CSL-19
13	Cap Screw	CSL-21

Seal Kit CSL-SKIT

ITEM	NAME	PART #
7	Swivel O-ring (Small)	CSL-11
8	Swivel O-ring (Large)	CSL-13
9	Post O-ring	CSL-15
10	Joint O-ring	CSL-17
12	Swivel Post Screw	CSL-23
13	Cap Screw	CSL-21

SQ Series Uni-Swivel Assembly

1. Clamp the post (1) in a copper-covered or leather-covered vice by the base.
2. Slide the post O-rings (9) onto the post starting from the top to the base.
3. Lightly lubricate the post.
4. Using hand pressure, press the joint (2) onto the post until it makes contact with the base of the post and until the top of the post is flush with the top of the joint.
5. **For CSS uni-swivels:** Install the retaining ring (5) into the groove on the top of the post by spreading it open slightly and working it around the post. **For CSL uni-swivels:** Install the cap (6) and secure with the cap screws (13).
6. Slide the joint O-rings (10) onto the arms of the joint from outside to inside.
7. Lightly lubricate the arms of the joint.
8. Using hand pressure, press the swivels (3 & 4) onto the joint. **Note:** One of the arms of the joint has an 'R' engraved on the end denoting that it is the retract side. Install the retract swivel (4) onto this arm.
9. Swing the arms together so they interlock and fasten them together with the swivel screw (11).
10. Install the large and small swivel O-rings (7 & 8) into their glands in the cylinder housing.
11. Install the uni-swivel assembly onto the cylinder housing with the swivel post screws (12).

SQ Series Wrench Available Accessories

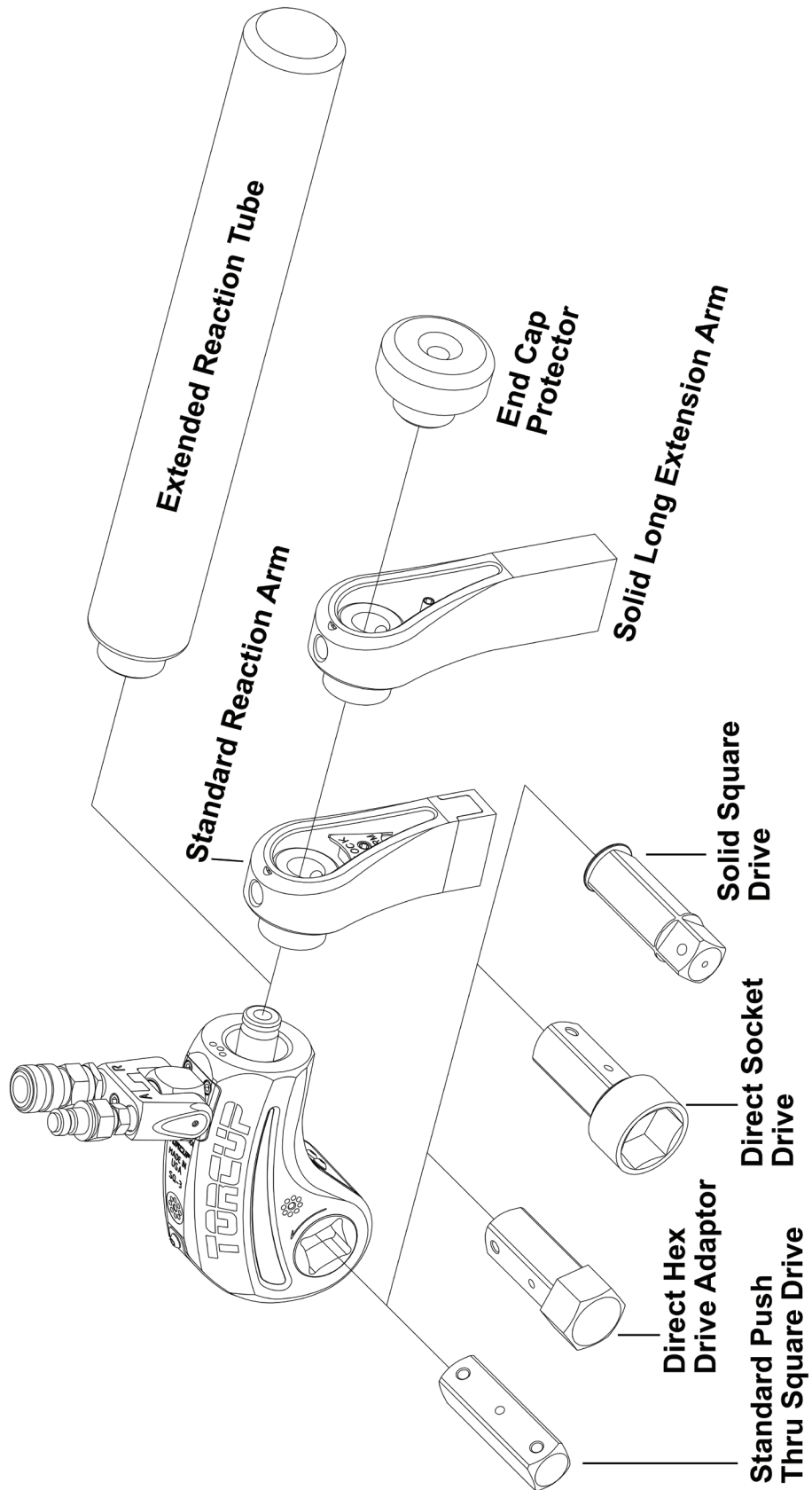

MAINTENANCE SECTION

WARNING

Always turn off the power supply. Bleed off hydraulic fluid from the hose connections on the cylinder assembly and disconnect the hoses before attempting to repair or perform maintenance on this tool. Always wear eye protection when operating or performing maintenance on this tool.

DISASSEMBLY

GENERAL INSTRUCTIONS

1. Do not disassemble the tool any further than necessary to replace or repair damaged parts.
2. Use extra care not to score, nick or damage surfaces that will contain hydraulic oil under pressure.
3. Whenever grasping a tool in a vise, always use leather-covered or copper-covered vise jaws to protect the surface of the part and help prevent distortion. This is particularly true of threaded members and housings.
4. Do not remove any part that is press fit in or on an assembly unless the removal of that part is necessary for repairs or replacement.
5. Do not disassemble the hydraulic cylinder assembly unless you have a complete set of seals and O-rings for replacement.
6. Use only British Standard fractional size tools when disassembling these tools.

DISASSEMBLY OF THE REACTION ARM ASSEMBLY

1. Push the reaction arm retract button cover (10) toward the reaction arm cover (8) and separate the reaction arm assembly from the housing (1).
2. While holding the button down, use a hex wrench to unscrew and remove the reaction arm spline screw (6).
3. Apply some downward pressure to the reaction arm locking pin (4) and unscrew the reaction arm retract button (10) from the locking pin (4).
4. Slide the retract button cover (10) out of the reaction arm (2).
5. Remove the locking pin (4) by sliding it out of the top of the reaction arm (2).
6. Pull the reaction arm splined sleeve (3) out of the reaction arm (2).
7. Using a hooked tool through the spline screw opening, pull the reaction arm spring (7) out of the reaction arm (2).
8. To remove the reaction arm cover, use a hex wrench to unscrew the cover mounting screws (9) and pull the cover (8) off the reaction arm (2).

CAUTION

In the following step, the shroud will spring to a straightened position when the screws at one end are removed. Hold the shroud in position until the screws are removed and control the flex of the loose end.

DISASSEMBLY OF THE SQ-1, SQ-3, AND SQ-10 CYLINDER ASSEMBLIES

1. Clamp the housing (1) in copper-covered or leather-covered vise jaws with the swivel assembly (40) upward and using a hex wrench, unscrew the four swivel screws (41) to remove the swivel assembly.
2. Collect the O-rings from the housing.
3. Use a hex wrench to unscrew and remove the shroud mounting screws (28). Remove the shroud (27). **Note: For SQ-10 models:** The middle drive side shroud screw holds the ratchet spring (38) in place, which will come out with the removal of the shroud.
4. Remove the housing assembly from the vise jaws and turn over a container to catch any oil remaining inside the cylinder.

MAINTENANCE SECTION

5. Remove the side labels to reveal housing side holes. **For SQ-10 models:** Use a hex wrench to unscrew and remove the side housing plugs (36) from each side of the housing.
6. If the piston assembly is not fully retracted, use a brass drift or brass hammer to tap the assembly inward until the roll pin (25) aligns with the cross holes in the housing. **Note:** Covering the swivel pocket with a cloth will contain any oil that may expel from the housing.
7. Use a small drift to tap the roll pin (25) out of the piston rod assembly (23) and drive plate (15).
8. Insert a hex wrench through the larger opening in the square drive and loosen the square drive locking pin (17) until the square drive slides out of the tool. **Note:** Use caution when removing the square drive as the square drive pin (18) loosely fits in the square drive and can fall out when the drive is removed.
9. Remove the drive plate (15), assembled with the ratchet (13), drive segment (14) and segment springs (29).
10. Using finger pressure, push the sleeves (21) inward to remove them from the housing.
11. Being careful not to let the springs eject from the assembly, slide the ratchet (13), drive segment (14) and segment springs (29) out of the drive plate (15).

NOTICE

The cylinder gland is staked into the housing to prevent it from loosening due to vibration or turbulence in the hydraulic oil flow. The stake point must be drilled out before attempting to remove the cylinder gland.

12. Locate the stake point on the threads of the cylinder gland (26) and housing. Using a 1/16" drill bit centered on the stake point, drill approximately 3/32" deep in one continuous motion to remove the thread and interference at that point.
13. Engage the pins of the cylinder gland wrench (50) with the holes in the cylinder gland (26). Using a socket on the hex of the wrench, unscrew and remove the cylinder gland. If the gland does not rotate freely after initial breakout, additional drilling, in small increments, may be required to remove the obstruction.
14. Clamp the housing in the vise with the end plug upward and a catch cloth draped between the jaws.
15. Insert a flat face drift into the hole in the center of the end plug (22). Tap the end plug and piston lightly until both the piston and end plug slip through the housing and into the catch cloth.
16. Being careful not to scratch the cylinder, remove the cylinder ring (37) using a thin blade screwdriver to work it out of the groove in the housing.

CAUTION

In the following step, the shroud will spring to a straightened position when the screws at one end are removed. Hold the shroud in position until the screws are removed and control the flex of the loose end.

DISASSEMBLY OF THE SQ-5 CYLINDER ASSEMBLIES

1. Clamp the housing (1) in copper-covered or leather-covered vise jaws with the swivel assembly (40) upward and using a hex wrench, unscrew the four swivel screws (41) to remove the swivel assembly.
2. Collect the O-rings from the housing.
3. Use a hex wrench to unscrew and remove the shroud mounting screws (28). Remove the shroud (27).
4. Remove the housing assembly from the vise jaws and turn over a container to catch any oil remaining inside the cylinder.
5. Remove the side labels to reveal housing side holes. Use a hex wrench to unscrew and remove the side housing plugs (36) from each side of the housing.

MAINTENANCE SECTION

6. If the piston assembly is not fully retracted, use a brass drift or brass hammer to tap the assembly inward until the roll pin (25) aligns with the cross holes in the housing. **Note:** Covering the swivel pocket with a cloth will contain any oil that may expel from the housing.
7. Use a small drift to tap the roll pin (25) out of the piston rod assembly (23) and drive plate (15).
8. Unscrew the square drive retaining knob (19). Pull out the square drive (16).
9. Remove the drive plate (15), assembled with the ratchet (13), drive segment (14), and segment springs (29).
10. Using finger pressure, push the sleeves (21) inward to remove them from the housing. Remove the sleeve retainers (20).
11. Being careful not to let the springs eject from the assembly, slide the ratchet (13), drive segment (14), and segment springs (29) out of the drive plate (15).

NOTICE

The cylinder gland is staked into the housing to prevent it from loosening due to vibration or turbulence in the hydraulic oil flow. The stake point must be drilled out before attempting to remove the cylinder gland.

12. Locate the stake point on the threads of the cylinder gland (26) and housing. Using a 1/16" drill bit centered on the stake point, drill approximately 3/32" deep in one continuous motion to remove the thread and interference at that point.
13. Engage the pins of the cylinder gland wrench (50) with the holes in the cylinder gland (26). Using a socket on the hex of the wrench, unscrew and remove the cylinder gland. If the gland does not rotate freely after initial breakout, additional drilling in small increments may be required to remove the obstruction.
14. Clamp the housing in the vise with the end plug upward and a catch cloth draped between the jaws.
15. Insert a flat face drift into the hole in the center of the end plug (22). Tap the end plug and piston lightly until both the piston and end plug slip through the housing and into the catch cloth.
16. Being careful not to scratch the cylinder, remove the cylinder ring (37) using a thin blade screwdriver to work it out of the groove in the housing

MAINTENANCE SECTION

ASSEMBLY

GENERAL INSTRUCTIONS

1. Use extra care not to score, nick, or damage surfaces that will contain hydraulic oil under pressure.
2. Whenever grasping a tool in a vise, always use leather-covered or copper-covered vise jaws to protect the surface of the part and help prevent distortion. This is particularly true of threaded members and housings.
3. Apply O-ring lubricant to all O-rings before final assembly.

NOTICE

Inspect all parts prior to assembly. Replace any worn or damaged parts.

ASSEMBLY OF THE SQ-1, SQ-3, AND SQ-10 CYLINDER ASSEMBLIES

1. Install the cylinder ring (37) into the groove at the inlet end of the housing.
2. Clamp the housing (1) in copper-covered or leather-covered vise jaws with the splined end downward.
3. Insert the end plug (22), small end leading, into the bore of the housing. Using a brass drift, tap the end plug into the cylinder approximately 1/2".
4. Insert the piston rod assembly (23), shaft trailing, into the bore of the housing. Using a brass drift, tap the piston rod assembly into the housing until the end plug bottoms out against the cylinder ring.
5. Thread the cylinder gland (26) into the housing. Tighten with the gland wrench (50) and a socket until flush with the housing.
6. Reposition the housing in the vice with the swivel pocket upward.
7. Place the swivel O-rings in their respective glands in the housing and install the swivel assembly. Tighten the swivel post screws (41) in a crossing pattern to ensure even tightness.
8. Connect the tool to a pump and cycle several times to check for leaks.
9. **If leaks are present**, disconnect the hoses and take the necessary steps to correct the problem. **If no leaks are detected**, disconnect the hoses and re-clamp the tool in the vise with the inlet end downward.
10. Stake the thread of the gland and housing. Make certain the stake point deforms both the housing and gland.
11. Wipe a thin film of marine moly grease on the sides of the drive plate (15) as well as the inner face and piston rod recess of the drive plate.
12. Insert the ratchet (13) into the drive plate (15).
13. Position the drive segment (14) at the cavity, ensuring the ratchet and drive segment engage properly. If they will not engage properly, reverse the ratchet in the drive plate.
14. Insert the segment springs (29) into the holes of the drive segment and compress while installing the drive segment into the drive plate.
15. Wipe a thin film of marine moly grease around the outside of the square drive sleeves (21) and install, with the shoulder trailing, into the bores on each side of the housing.
16. Insert the drive plate assembly into the housing with the notch for the piston rod toward the piston, ensuring alignment of the holes in the drive plate and piston.
17. Insert the roll pin (25) into the hole in the drive plate through the hole in the housing. Use a drift and hammer to tap the pin into the plate making certain the pin does not protrude beyond either side of the drive plate.
18. Use a hex wrench to loosen the square drive locking pin (17) enough so that the square drive pin is flush with the square drive.
19. Insert the square drive into the housing through the square drive sleeves (21) and tighten the square drive locking pin so that the square drive can slide freely without sliding out.

MAINTENANCE SECTION

20. Place one end of the shroud (27) on the housing and, using a hex wrench, thread the shroud screws (28) part way in.
21. Bend the shroud around the housing and install the remaining screws, going back and tightening the screws from the previous step.
22. Completely remove all dirt and oil from label pocket before applying the side labels.

NOTICE

Inspect all parts prior to assembly. Replace any worn or damaged parts.

ASSEMBLY OF THE SQ-5 CYLINDER ASSEMBLIES

1. Install the cylinder ring (37) into the groove at the inlet end of the housing.
2. Clamp the housing (1) in copper-covered or leather-covered vise jaws with the splined end downward.
3. Insert the end plug (22), small end leading, into the bore of the housing. Using a brass drift, tap the end plug into the cylinder approximately 1/2".
4. Insert the piston rod assembly (23), shaft trailing, into the bore of the housing. Using a brass drift, tap the piston rod assembly into the housing until the end plug bottoms out against the cylinder ring.
5. Thread the cylinder gland (26) into the housing. Tighten with the gland wrench (50) and a socket until flush with the housing.
6. Reposition the housing in the vice with the swivel pocket upward.
7. Place the swivel O-rings in their respective glands in the housing and install the swivel assembly (40). Tighten the swivel screws (41) in a crossing pattern to ensure even tightness.
8. Connect the tool to a pump and cycle several times to check for leaks.
9. **If leaks are present**, disconnect the hoses and take the necessary steps to correct the problem. **If no leaks are detected**, disconnect the hoses and re-clamp the tool in the vise with the inlet end downward.
10. Stake the thread of the gland and housing. Make certain the stake point deforms both the housing and gland.
11. Wipe a thin film of marine moly grease on the sides of the drive plate (15) as well as the inner face and piston rod recess of the drive plate.
12. Insert the ratchet (13) into the drive plate (15).
13. Position the drive segment (14) at the cavity, ensuring the ratchet and drive segment engage properly. If they will not engage properly, reverse the ratchet in the drive plate.
14. Insert the segment springs (29) into the holes of the drive segment and compress while installing the drive segment into the drive plate.
15. Insert the drive plate assembly into the housing with the notch for the piston rod toward the piston, ensuring alignment of the holes in the drive plate and piston.
16. Install the square drive sleeves (21) with the small hub end leading. The small hub must engage the recess in the drive plate assembly. Install the sleeve retaining rings (20).
17. Insert the square drive (16) into the housing through the drive sleeves (21). Install the square drive retaining knob (19) in the end of the square drive and tighten.
18. Insert the roll pin (25) into the hole in the drive plate through the hole in the housing. Use a drift and hammer to tap the pin into the plate making certain the pin does not protrude beyond either side of the drive plate.
19. Place one end of the shroud (27) on the housing and, using a hex wrench, thread the shroud screws (28) part way in.
20. Bend the shroud around the housing and install the remaining screws, going back and tightening the screws from the previous step.
21. Completely remove all dirt and oil from label pocket before applying the side labels.

MAINTENANCE SECTION

ASSEMBLY OF THE SQ REACTION ARM

1. If the reaction arm cover was removed, push it onto the end of the reaction arm and secure with the cover screws.
2. Insert the reaction arm spring into the blind hole below the bore for the spline sleeve.
3. Push the spline sleeve into the reaction arm so that the holes in the sleeve align with the reaction arm screw hole and the sleeve protrudes from the back of the arm.
4. Insert the locking pin into the reaction arm through the reaction arm screw opening, ensuring the screw hole is accessible through the slot in the reaction arm.
5. **For SQ-10 model only:** Install the retract button guide screw, applying a small amount of serviceable thread locking compound to the threads.
6. Install the retract button cover in the slots in the inside pocket of the reaction arm.
7. Apply some downward pressure to the locking pin, and thread the retract button through the retract button cover and into the locking pin through the slot in the reaction arm. Use a small amount of serviceable thread locking compound on the threads and tighten.
8. Thread the reaction arm screw into the reaction arm and tighten with a hex wrench until the unthreaded end enters the hole in the spline sleeve and the threads bottom out.

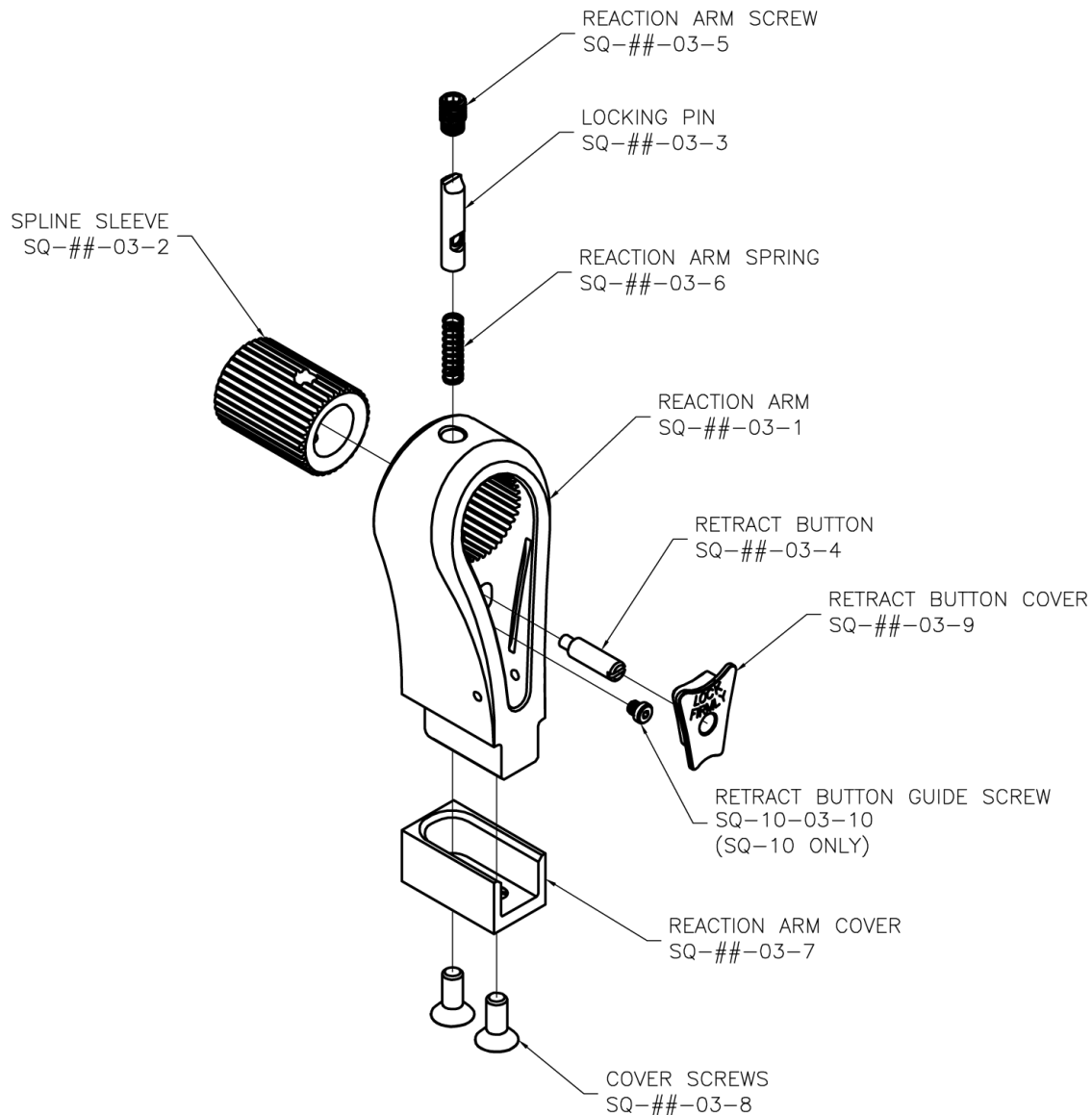

TROUBLESHOOTING GUIDE

Trouble	Probable Cause	Solution
Piston will not advance or retract	Couplers are not securely attached to the tool or pump	Check the coupler connections, and make certain that they are connected.
	Coupler is defective	Replace any defective coupler.
	Defective remote control switch	Replace the switch and/or control pendant.
	Dirt in the direction-control valve of the pump unit	Disassemble the pump, and clean the direction-control valve.
Piston will not retract	Hose connections reversed	Make certain the advance on the pump is connected to the advance on the tool, and the retract on the pump is connected to the retract on the tool.
	Retract hose not connected	Connect the retract hose securely.
	Retract pin broken	Replace the broken pin and/or spring.
Cylinder will not build up pressure	Piston seal and/or end plug Seal leaking	Replace any defective O-rings.
	Coupler is defective	Replace any defective coupler.
Square drive will not turn	Grease or dirt build up in the teeth of the ratchet and drive segment	Disassemble the ratchet and clean the grease or dirt out of the teeth.
	Worn or broken teeth on ratchet an/or drive segment	Replace any worn or damaged parts.
Tool tightens immediately when turned on	Hose connections are reversed	Depress the advance button to release the tool; shut the pump off in the advance position and reverse the hose connection.
Pump will not build up pressure	Defective relief valve	Inspect, adjust or replace the relief valve.
	Clogged filter	Inspect, clean and/or replace the pump filter.
	Electric power source is too low	Make certain the amperage, voltage and any extension cord size comply with the pump manual requirements.
	Defective gauge	Replace the gauge.
	Low oil level	Check and fill the pump reservoir.
Pressure reading erratic	Defective gauge	Replace the gauge.
Nut returns with retract stroke	Retract spring is not installed correctly.	Segment spring not installed or broken.

