

TX Series

OPERATION AND MAINTENANCE

MANUAL

TX Series

Low Profile Hydraulic Torque Wrenches

MODELS TX-1, TX-2, TX-4, TX-8, TX-16, TX-32, TX-45



1025 Conroy Place, Easton PA 18040 U.S.A.

Phone: +1 610-250-5800
Fax: +1 610-250-2700
Toll Free: 1-888-TORCUP-1
Email: sales@torcup.com
Website: www.torcup.com



NOTICE

Series TX-1, TX-2, TX-4, TX-8, TX-16, TX-32 and TX-45 Low Profile Hydraulic Torque Wrenches are designed for installing and removing threaded fasteners having minimal wrench clearance and requiring precise high torque during bolt makeup and maximum torque for bolt breakout.

TorcUP Inc. is not responsible for customer modification of tools for applications on which TorcUP Inc. was not consulted.

WARNING

**IMPORTANT SAFETY INFORMATION ENCLOSED.
READ THIS MANUAL BEFORE OPERATING TOOL.**

**IT IS THE RESPONSIBILITY OF THE EMPLOYER TO PLACE THE INFORMATION IN THIS
MANUAL INTO THE HANDS OF THE OPERATOR.**

FAILURE TO OBSERVE THE FOLLOWING WARNINGS COULD RESULT IN INJURY.

USING THE TOOL

- Always operate, inspect and maintain this tool in accordance with American National Standards Safety Code for Hydraulic Rams and Jacks (ANSI B30.1).
- This tool will function using an air or electric powered hydraulic pump. Adhere to the pump safety requirements and follow instructions when connecting the pump to the tool.
- Use only equipment rated for the same pressure and torque.
- Use only a hydraulic pump capable of generating 10,000 psi (681 bar) maximum pressure with this tool.
- Use only twin line hydraulic hose rated for 10,000 psi (681 bar) pressure with this tool.
- Do not interchange the male and female swivel inlets on the tool or the connections on one end of the hose. Reversing the inlets will reverse the power stroke cycle and may damage the tool.
- Do not use damaged, frayed or deteriorated hoses and fittings. Make certain there are no cracks, splits or leaks in the hoses.
- Use the quick connect system to attach the hoses to the tool and pump.
- When connecting hoses that have not been preloaded with hydraulic oil, make certain the pump reservoir is not drained of oil during start-up.
- Do not remove any labels. Replace any damaged label.
- Do not handle pressurized hoses. Escaping oil under pressure can penetrate the skin, causing serious injury. If oil is injected under the skin, see a doctor immediately.
- Never pressurize uncoupled couplers. Only use hydraulic equipment in a coupled system.
- Always wear eye protection when operating or performing maintenance on this tool.
- Always wear head and hand protection and protective clothing when operating this tool.

The use of other than genuine TorcUP replacement parts may result in safety hazards, decreased tool performance, increased maintenance, and may invalidate all warranties. Repairs should be made only by authorized personnel. Consult your nearest TorcUP Authorized Service Center.

Refer All Communications to the Nearest TorcUP Office or Distributor.

For Technical Support & Information Contact:

TorcUP Inc.

1025 Conroy Place, Easton, PA 18040 USA

Phone: +1 610-250-5800 Fax: +1 610-250-2700

email: sales@torcup.com

WARNING

FAILURE TO OBSERVE THE FOLLOWING WARNINGS COULD RESULT IN INJURY

Do NOT Exceed Maximum Pressure. See Torque Chart with Tool. Damage May Occur.

Do not use damaged, frayed or deteriorated hydraulic hoses and fittings.



Always wear eye protection when operating or performing maintenance on this tool.



Always wear ear protection when operating this tool.



Do not carry the tool by the hose.



Keep body stance balanced and firm. Do not overreach when operating this tool.



The Torque Reaction Arm must be positioned against a positive stop. Do not use the arm as a dead handle. Take all precautions to make certain the operator's hand cannot be pinched between the arm and a solid object.



USING THE TOOL

- Keep hands, loose clothing and long hair away from the reaction arm and working area during operation.
- This tool will exert a strong reaction force. Use proper mechanical support and correct reaction arm positioning to control these forces. Do not position the reaction arm so that it tilts the tool off the axis of the bolt and never use the swivel inlets as a reaction stop.
- Avoid sharp bends and kinks that will cause severe back-up pressure in hoses and lead to premature hose failure.
- Use accessories recommended by TorcUP.
- Use only impact sockets and accessories. Do not use hand (chrome) sockets or accessories.
- Use only sockets and accessories that correctly fit the bolt or nut and function without tilting the tool off the axis of the bolt.
- This tool is not insulated against electric shock.
- This equipment must not be operated or serviced unless the operator read the operating instructions and fully understands the purpose, consequences and procedure of each step.
- When operating a larger tool (TX-16, TX-32, or TX-45) above waist height, employ a secondary means of support for safety purposes. A tool sling or chains may be used. Consult your safety department for further suggestions.

Depending on the working environment your local health and safety regulations may require you wear protective gear (i.e. safety shoes, hard hat, gloves, coveralls, etc.). In case external forces are exerted on the equipment, non-compliance with these regulations may result in injury. **EAR PROTECTION MUST BE WORN WHEN OPERATING THIS TOOL.**

PLACING THE TOOL IN SERVICE

CONNECTING THE TOOL

1. Attach the twin line hose to the swivel inlets of the square drive torque wrench using the spring-loaded quick connect ends.
2. Connect the opposite ends of the hose to the pump in the same manner.
3. Push the link retaining pin out of the low profile drive cylinder.
4. Mate the selected ratchet link to the cylinder by inserting the end of the cylinder opposite the swivel inlets between the side plates of the ratchet link. (Refer to Dwg. 1)
5. Align the holes for the link retaining pin and insert the pin through the side plates and cylinder to keep the units joined together.

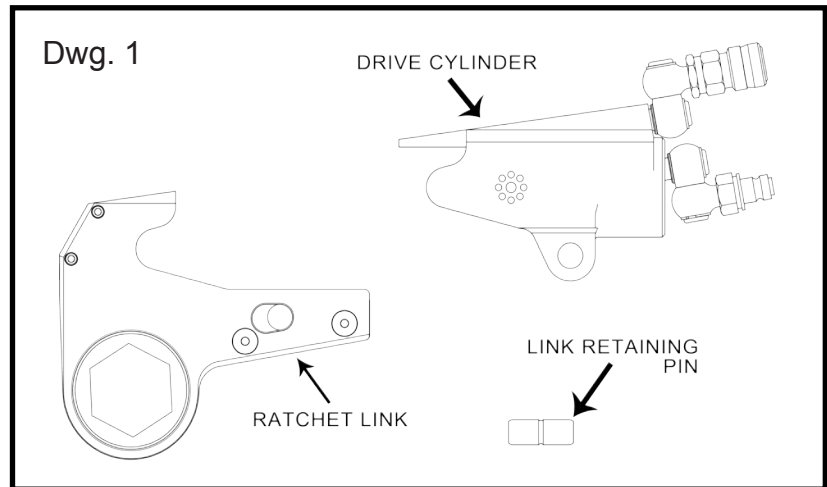

SETTING THE TORQUE

After determining the desired torque, use the torque conversion charts on pages 7 to 20 to determine the pressure that is necessary to achieve that torque.

1. Connect the tool to the power supply and turn the pump on.
2. Depress the remote control button causing the pressure to be shown on the gauge.
3. Adjust the pressure by loosening the wing nut that locks the pressure adjustment thumbscrew. Rotate the thumbscrew clockwise to increase the pressure and counterclockwise to decrease the pressure. When decreasing pressure, always lower the pressure below the desired point and then bring the gauge back up to the desired pressure.
4. When the desired pressure is reached, retighten the wing nut and cycle the tool again to confirm that the desired pressure setting has been obtained.

OPERATING THE WRENCH

The position of the tool relative to the nut determines whether the action will tighten or loosen the nut. (Refer to Dwg. 2 for application examples). The power stroke of the piston assembly will always turn the ratchet hex toward the shroud.

1. Place the ratchet hex on the nut. Make certain it is the correct size for the nut and that it fully engages the nut.
2. Position the reaction surface against an adjacent nut, flange or solid system component. Make certain that there is clearance for the hoses, swivels, and inlets. **DO NOT** allow the tool to react against the hoses, swivels, or inlets.

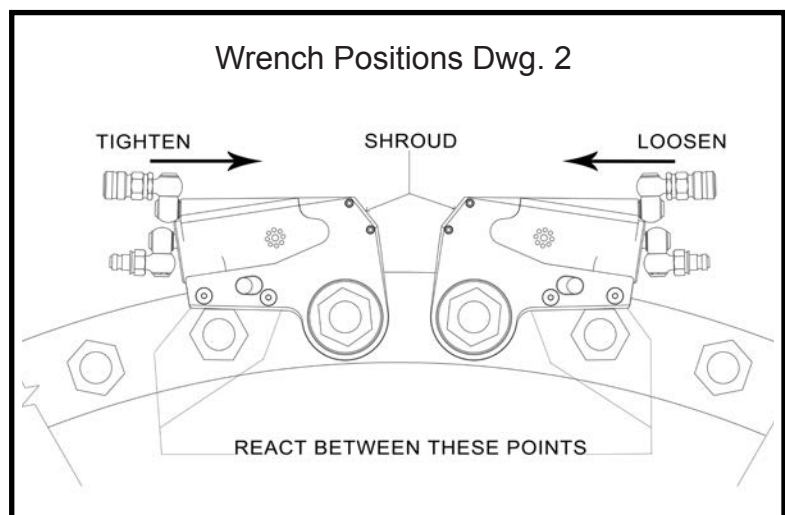

PLACING THE TOOL IN SERVICE

3. After having turned the pump on and presetting the pressure for the correct torque, depress the remote control button to advance the piston assembly. If the notch in the piston rod did not engage the retract pin in the ratchet link when the link was joined to the housing, it will engage the pin automatically during the first advance stroke.
4. When the link is connected to the cylinder and the wrench is started, the reaction surface of the wrench will move against the contact point and the nut will begin to turn.
5. When the nut is no longer turning and the pump gauge reaches the preset pressure, release the remote control button. The piston rod will retract when the button is released. Under normal conditions, an audible “click” will be heard as the tool resets itself.
6. Continue to cycle the tool until it “stalls” and the preset psi/torque has been attained.
7. Cycle the tool one last time to ensure full total torque.

LUBRICATION

MARINE MOLY GREASE

Lubrication frequency is dependent on factors known only to the user. The amount of contaminants in the work area is one factor. Tools used in a clean room environment will obviously require less service than a tool used outdoors and dropped in loose dirt or sand. Marine Moly Grease is formulated not to wash out of the tool in areas where lubrication is critical. Whenever lubrication is required, lubricate as follows:

1. Separate the low profile cylinder from the ratchet link if they are joined.
2. After wiping off the old grease, apply a daub of Marine Moly Grease to the hooking notch on the piston rod and wipe a film of Marine Moly Grease onto the sides and faces of the two sliders.
3. Disassemble the ratchet link as instructed in the Maintenance Section and wash the components in a suitable cleaning solution in a well ventilated area.
4. Dry the components, then wipe a film of Marine Moly Grease onto the wear surface of both side plate sleeves and the hubs of the ratchet.
5. Spread a light film of Marine Moly Grease onto the inner faces of both side plates covering the area where the drive plate and drive segment travel. DO NOT pack the teeth of the drive segment or ratchet with lube. It can prevent the teeth from engaging properly.
6. Reassemble the ratchet link as instructed in the Maintenance Section.

TX Series Wrench Technical & Dimensional Data

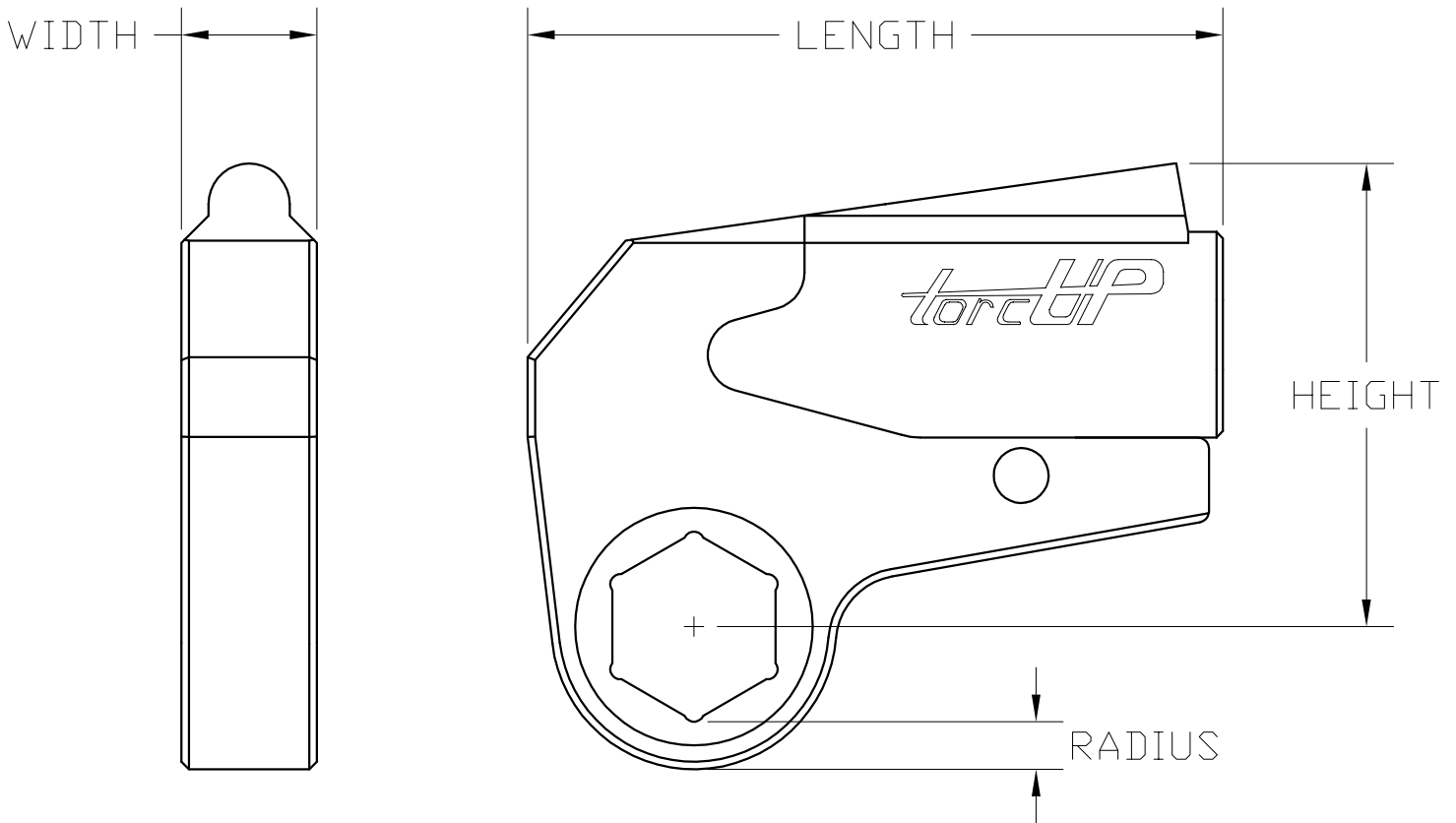

Model Number	TX-1	TX-2	TX-4	TX-8
Min. Torque (ft/lbs)	45	192	395	830
Max. Torque (ft/lbs)	560	1928	3950	8630
Min. Torque (nm)	61	260	535	1125
Max. Torque (nm)	759	2614	5355	11699
Output Accuracy	+/-3%	+/-3%	+/-3%	+/-3%
Repeatability	100%	100%	100%	100%
Duty Cycle	100%	100%	100%	100%
Cylinder Weight (lbs/kg)	1.0/0.5	3.5/1.6	6.0/2.7	11.7/5.0
Link Weight (lbs)	1.0-1.0	2.4-3.5	5.4-7.6	11.9-14.5
(kg)	0.45-0.45	1.0-1.5	2.4-3.4	5.5-6.5
Length (in/mm)	4.37/111.0	6.45/163.8	7.87/199.9	10.18/258.6
Width (in/mm)	0.78/19.8	1.25/31.8	1.63/41.4	2.05/52.1
Radius (in/mm)	0.23/5.8	0.36/9.1	0.46/11.7	0.54/13.7
Height (in/mm)	3.25/82.6	4.00/101.6	5.60/142.2	7.00/177.8
Hex Range From	1/2"/13mm	3/4"/19mm	1"/27mm	1 7/8"/49mm
Hex Range To	2"/50mm	2 9/16"/65mm	3 1/8"/80mm	4 5/8"/120mm

TX Series Wrench Technical & Dimensional Data

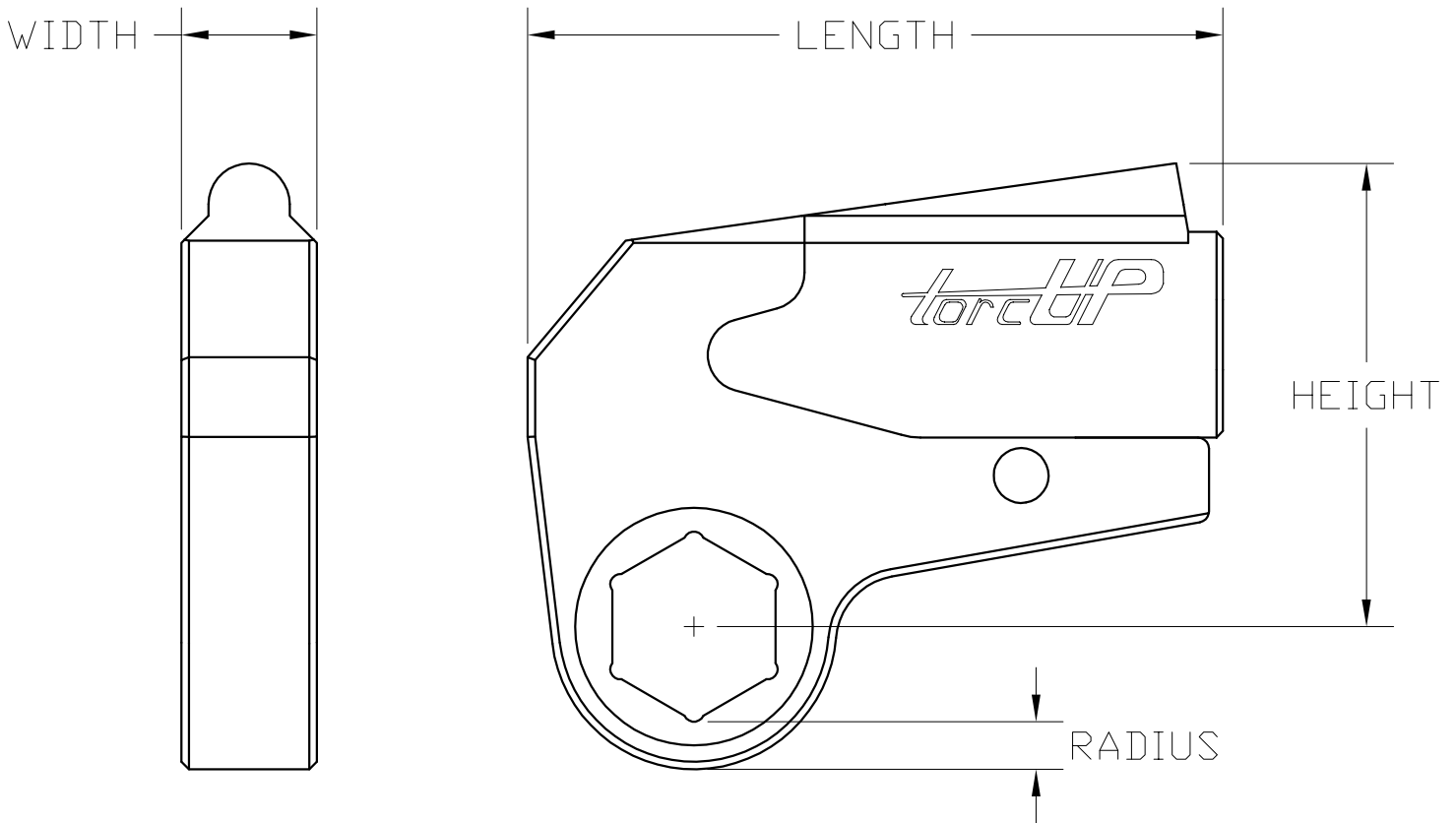

Model Number	TX-16	TX-32	TX-45
Min. Torque (ft/lbs)	1560	3220	4850
Max. Torque (ft/lbs)	16600	35650	47380
Min. Torque (nm)	2115	4365	6575
Max. Torque (nm)	22503	48327	64239
Output Accuracy	+/-3%	+/-3%	+/-3%
Repeatability	100%	100%	100%
Duty Cycle	100%	100%	100%
Cylinder Weight (lbs/kg)	16.0/7.3	26.0/11.5	29.0/13.0
Link Weight (lbs)	21.0-28.0	29.0-39.5	29.0-39.5
(kg)	9.5-13.0	13.0-17.9	13.0-17.9
Length (in/mm)	12.93/328.4	15.80/401.3	16.75/425.5
Width (in/mm)	2.50/63.5	3.24/82.3	4.88/124.0
Radius (in/mm)	0.65/16.5	0.93/23.6	0.93/23.6
Height (in/mm)	7.58/192.5	9.50/241.3	10.28/261.1
Hex Range From	2 3/16"/55mm	3 1/8"/80mm	3 1/8"/80mm
Hex Range To	5 5/16"/135mm	7 7/8"/200mm	7 7/8"/200mm



TORQUE

TX-1 Torque Conversion Chart (Imperial)

	Imperial Conversion			Imperial Conversion			Imperial Conversion	
	PSI	Ft-lbs		PSI	Ft-lbs		PSI	Ft-lbs
	Hex Range 1/2" - 1 1/8"	1,000		55	Hex Range 1 3/16" - 1 13/16"		1,000	71
1,200		64	1,200	83		1,200	92	
1,400		74	1,400	95		1,400	105	
1,600		83	1,600	106		1,600	118	
1,800		92	1,800	118		1,800	131	
2,000		101	2,000	130		2,000	144	
2,200		110	2,200	142		2,200	158	
2,400		119	2,400	154		2,400	171	
2,600		129	2,600	165		2,600	184	
2,800		138	2,800	177		2,800	197	
3,000		147	3,000	189		3,000	210	
3,200		156	3,200	200		3,200	223	
3,400		165	3,400	212		3,400	235	
3,600		174	3,600	223		3,600	248	
3,800		182	3,800	235		3,800	261	
4,000		191	4,000	246		4,000	273	
4,200		200	4,200	258		4,200	286	
4,400		209	4,400	269		4,400	299	
4,600		218	4,600	281		4,600	312	
4,800		227	4,800	292		4,800	325	
5,000		236	5,000	304		5,000	338	
5,200		245	5,200	316		5,200	351	
5,400		254	5,400	327		5,400	364	
5,600		264	5,600	339		5,600	376	
5,800		273	5,800	350		5,800	389	
6,000		282	6,000	362		6,000	402	
6,200		291	6,200	374		6,200	415	
6,400		300	6,400	385		6,400	428	
6,600		309	6,600	397		6,600	441	
6,800		318	6,800	408		6,800	454	
7,000		327	7,000	420		7,000	467	
7,200		336	7,200	431		7,200	479	
7,400		344	7,400	443		7,400	492	
7,600	353	7,600	454	7,600	505			
7,800	362	7,800	466	7,800	517			
8,000	371	8,000	477	8,000	530			
8,200	380	8,200	489	8,200	543			
8,400	389	8,400	501	8,400	556			
8,600	399	8,600	512	8,600	569			
8,800	408	8,800	524	8,800	582			
9,000	417	9,000	536	9,000	596			
9,200	426	9,200	547	9,200	608			
9,400	435	9,400	559	9,400	621			
9,600	443	9,600	570	9,600	634			
9,800	452	9,800	582	9,800	646			
10,000	461	10,000	593	10,000	659			

For reference purposes only, please consult the calibration chart specific to your purchase or rental tool.



TORCUP

TX-1 Torque Conversion Chart (Metric)

	Metric Conversion			Metric Conversion			Metric Conversion	
	Bar	Nm		Bar	Nm		Bar	Nm
	Hex Range 13-28mm	69		75	Hex Range 29-46mm		69	96
83		87	83	112		83	125	
97		100	97	128		97	143	
110		112	110	144		110	160	
124		125	124	160		124	178	
138		137	138	176		138	196	
152		150	152	192		152	214	
165		162	165	208		165	231	
179		174	179	224		179	249	
193		187	193	240		193	267	
207		199	207	256		207	285	
221		211	221	272		221	302	
234		223	234	287		234	319	
248		235	248	303		248	336	
262		247	262	318		262	353	
276		259	276	334		276	371	
290		272	290	349		290	388	
303		284	303	365		303	406	
317		296	317	381		317	423	
331		308	331	396		331	440	
345		321	345	412		345	458	
359		333	359	428		359	475	
372		345	372	444		372	493	
386		357	386	459		386	510	
400		370	400	475		400	528	
414		382	414	491		414	545	
427		394	427	507		427	563	
441		406	441	522		441	580	
455		418	455	538		455	598	
469		431	469	554		469	615	
483		443	483	569		483	633	
496		455	496	585		496	650	
510		467	510	600		510	667	
524		479	524	616		524	684	
538		491	538	631		538	701	
552		503	552	647		552	719	
565	515	565	663	565	736			
579	528	579	679	579	754			
593	540	593	695	593	772			
607	553	607	711	607	790			
621	565	621	727	621	807			
634	577	634	742	634	825			
648	589	648	758	648	842			
662	601	662	773	662	859			
676	613	676	789	676	876			
689	625	689	804	689	893			

For reference purposes only, please consult the calibration chart specific to your purchase or rental tool.



TORCLIP

TX-2 Torque Conversion Chart (Imperial)

	Imperial Conversion	
	PSI	Ft-lbs
Hex Range 3/4" - 1 13/16"	1,000	202
	1,200	240
	1,400	278
	1,600	317
	1,800	355
	2,000	393
	2,200	432
	2,400	471
	2,600	511
	2,800	550
	3,000	589
	3,200	629
	3,400	669
	3,600	708
	3,800	748
	4,000	788
	4,200	827
	4,400	867
	4,600	906
	4,800	946
	5,000	985
	5,200	1024
	5,400	1064
	5,600	1103
	5,800	1142
	6,000	1182
	6,200	1222
	6,400	1261
	6,600	1301
	6,800	1341
	7,000	1381
	7,200	1421
7,400	1461	
7,600	1500	
7,800	1540	
8,000	1579	
8,200	1619	
8,400	1658	
8,600	1697	
8,800	1737	
9,000	1776	
9,200	1814	
9,400	1853	
9,600	1892	
9,800	1930	
10,000	1969	

	Imperial Conversion	
	PSI	Ft-lbs
Hex Range 1 7/8" - 2 9/16"	1,000	237
	1,200	282
	1,400	326
	1,600	371
	1,800	415
	2,000	460
	2,200	506
	2,400	552
	2,600	598
	2,800	644
	3,000	690
	3,200	737
	3,400	783
	3,600	830
	3,800	876
	4,000	923
	4,200	969
	4,400	1015
	4,600	1062
	4,800	1108
	5,000	1154
	5,200	1200
	5,400	1246
	5,600	1292
	5,800	1338
	6,000	1384
	6,200	1431
	6,400	1478
	6,600	1524
	6,800	1571
	7,000	1618
	7,200	1664
7,400	1711	
7,600	1757	
7,800	1804	
8,000	1850	
8,200	1896	
8,400	1942	
8,600	1988	
8,800	2034	
9,000	2080	
9,200	2125	
9,400	2170	
9,600	2216	
9,800	2261	
10,000	2306	

For reference purposes only, please consult the calibration chart specific to your purchase or rental tool.



TORCLIP

TX-2 Torque Conversion Chart (Metric)

	Metric Conversion			Metric Conversion	
	Bar	Nm		Bar	Nm
Hex Range 19-46mm	69	274	Hex Range 47-65mm	69	321
	83	326		83	382
	97	378		97	442
	110	429		110	503
	124	481		124	563
	138	532		138	624
	152	586		152	686
	165	639		165	748
	179	692		179	811
	193	745		193	873
	207	799		207	936
	221	853		221	999
	234	907		234	1062
	248	961		248	1125
	262	1014		262	1188
	276	1068		276	1251
	290	1122		290	1314
	303	1175		303	1377
	317	1229		317	1439
	331	1282		331	1502
	345	1336		345	1565
	359	1389		359	1627
	372	1442		372	1689
	386	1496		386	1752
	400	1549		400	1814
	414	1602		414	1876
	427	1656		427	1940
	441	1710		441	2003
	455	1765		455	2067
	469	1819		469	2130
	483	1873		483	2194
	496	1927		496	2257
	510	1980		510	2320
	524	2034		524	2382
538	2088	538	2445		
552	2141	552	2508		
565	2195	565	2571		
579	2248	579	2633		
593	2301	593	2695		
607	2354	607	2758		
621	2408	621	2820		
634	2460	634	2881		
648	2512	648	2943		
662	2565	662	3004		
676	2617	676	3065		
689	2669	689	3127		

For reference purposes only, please consult the calibration chart specific to your purchase or rental



TORQUE

TX-4 Torque Conversion Chart (Imperial)

	Imperial Conversion			Imperial Conversion	
	PSI	Ft-lbs		PSI	Ft-lbs
Hex Range 1" - 2 9/16"	1,000	422	Hex Range 2 5/8" - 3 1/8"	1,000	475
	1,200	502		1,200	565
	1,400	582		1,400	655
	1,600	663		1,600	745
	1,800	743		1,800	836
	2,000	823		2,000	926
	2,200	906		2,200	1019
	2,400	989		2,400	1112
	2,600	1072		2,600	1206
	2,800	1155		2,800	1299
	3,000	1238		3,000	1393
	3,200	1320		3,200	1484
	3,400	1401		3,400	1576
	3,600	1483		3,600	1668
	3,800	1564		3,800	1760
	4,000	1646		4,000	1852
	4,200	1726		4,200	1942
	4,400	1806		4,400	2032
	4,600	1887		4,600	2122
	4,800	1967		4,800	2212
	5,000	2047		5,000	2303
	5,200	2128		5,200	2393
	5,400	2209		5,400	2484
	5,600	2289		5,600	2575
	5,800	2370		5,800	2666
	6,000	2451		6,000	2757
	6,200	2533		6,200	2849
	6,400	2615		6,400	2942
	6,600	2698		6,600	3034
	6,800	2780		6,800	3127
	7,000	2862		7,000	3219
	7,200	2942		7,200	3309
7,400	3021	7,400	3398		
7,600	3101	7,600	3488		
7,800	3180	7,800	3577		
8,000	3260	8,000	3667		
8,200	3343	8,200	3761		
8,400	3426	8,400	3854		
8,600	3510	8,600	3948		
8,800	3593	8,800	4041		
9,000	3676	9,000	4135		
9,200	3758	9,200	4227		
9,400	3840	9,400	4319		
9,600	3922	9,600	4412		
9,800	4004	9,800	4504		
10,000	4086	10,000	4596		

For reference purposes only, please consult the calibration chart specific to your purchase or rental tool.



TORQUE

TX-4 Torque Conversion Chart (Metric)

	Metric Conversion			Metric Conversion	
	Bar	Nm		Bar	Nm
Hex Range 27-65mm	69	572	Hex Range 66-80mm	69	644
	83	681		83	766
	97	790		97	888
	110	898		110	1011
	124	1007		124	1133
	138	1116		138	1255
	152	1228		152	1382
	165	1341		165	1508
	179	1453		179	1635
	193	1566		193	1761
	207	1679		207	1888
	221	1789		221	2013
	234	1900		234	2137
	248	2010		248	2261
	262	2121		262	2386
	276	2232		276	2510
	290	2340		290	2633
	303	2449		303	2755
	317	2558		317	2877
	331	2667		331	3000
	345	2775		345	3122
	359	2885		359	3245
	372	2994		372	3368
	386	3104		386	3492
	400	3214		400	3615
	414	3323		414	3738
	427	3435		427	3863
	441	3546		441	3989
	455	3657		455	4114
	469	3769		469	4239
	483	3880		483	4365
	496	3988		496	4486
510	4096	510	4608		
524	4204	524	4729		
538	4312	538	4850		
552	4420	552	4972		
565	4533	565	5099		
579	4646	579	5226		
593	4758	593	5352		
607	4871	607	5479		
621	4984	621	5606		
634	5095	634	5731		
648	5206	648	5856		
662	5318	662	5981		
676	5429	676	6107		
689	5540	689	6232		

For reference purposes only, please consult the calibration chart specific to your purchase or rental tool.



TORQUE

TX-8 Torque Conversion Chart (Imperial)

	Imperial Conversion			Imperial Conversion			Imperial Conversion	
	PSI	Ft-lbs		PSI	Ft-lbs		PSI	Ft-lbs
	Hex Range 1 7/8" - 3 1/8"	1,000		797	Hex Range 3 3/16" - 3 9/16"		1,000	842
1,200		957	1,200	1011		1,200	1174	
1,400		1117	1,400	1180		1,400	1370	
1,600		1277	1,600	1350		1,600	1567	
1,800		1437	1,800	1519		1,800	1763	
2,000		1597	2,000	1688		2,000	1960	
2,200		1758	2,200	1858		2,200	2157	
2,400		1918	2,400	2027		2,400	2353	
2,600		2079	2,600	2197		2,600	2550	
2,800		2239	2,800	2366		2,800	2747	
3,000		2400	3,000	2536		3,000	2944	
3,200		2559	3,200	2704		3,200	3140	
3,400		2719	3,400	2873		3,400	3335	
3,600		2878	3,600	3041		3,600	3531	
3,800		3037	3,800	3210		3,800	3726	
4,000		3197	4,000	3378		4,000	3922	
4,200		3354	4,200	3544		4,200	4114	
4,400		3511	4,400	3710		4,400	4307	
4,600		3668	4,600	3876		4,600	4500	
4,800		3825	4,800	4042		4,800	4693	
5,000		3982	5,000	4208		5,000	4885	
5,200		4143	5,200	4377		5,200	5082	
5,400		4303	5,400	4547		5,400	5279	
5,600		4463	5,600	4716		5,600	5475	
5,800		4623	5,800	4886		5,800	5672	
6,000		4784	6,000	5055		6,000	5869	
6,200		4946	6,200	5227		6,200	6068	
6,400		5109	6,400	5399		6,400	6267	
6,600		5272	6,600	5570		6,600	6467	
6,800		5434	6,800	5742		6,800	6666	
7,000	5597	7,000	5914	7,000	6866			
7,200	5756	7,200	6083	7,200	7062			
7,400	5916	7,400	6252	7,400	7258			
7,600	6076	7,600	6420	7,600	7454			
7,800	6236	7,800	6589	7,800	7650			
8,000	6395	8,000	6758	8,000	7846			
8,200	6564	8,200	6936	8,200	8052			
8,400	6732	8,400	7113	8,400	8258			
8,600	6900	8,600	7291	8,600	8464			
8,800	7068	8,800	7468	8,800	8670			
9,000	7236	9,000	7646	9,000	8877			
9,200	7393	9,200	7813	9,200	9070			
9,400	7551	9,400	7979	9,400	9263			
9,600	7709	9,600	8146	9,600	9457			
9,800	7866	9,800	8312	9,800	9650			
10,000	8024	10,000	8479	10,000	9844			

For reference purposes only, please consult the calibration chart specific to your purchase or rental tool.



TORQUE

TX-8 Torque Conversion Chart (Metric)

	Metric Conversion			Metric Conversion			Metric Conversion	
	Bar	Nm		Bar	Nm		Bar	Nm
	Hex Range 49-80mm	69		1080	Hex Range 81-90mm		69	1142
83		1297	83	1371		83	1592	
97		1515	97	1600		97	1858	
110		1732	110	1830		110	2124	
124		1949	124	2059		124	2391	
138		2166	138	2289		138	2657	
152		2383	152	2519		152	2924	
165		2601	165	2749		165	3191	
179		2819	179	2978		179	3458	
193		3036	193	3208		193	3725	
207		3254	207	3438		207	3992	
221		3470	221	3667		221	4257	
234		3686	234	3895		234	4522	
248		3902	248	4123		248	4787	
262		4118	262	4352		262	5052	
276		4334	276	4580		276	5317	
290		4547	290	4805		290	5578	
303		4760	303	5030		303	5840	
317		4973	317	5255		317	6101	
331		5186	331	5480		331	6362	
345		5399	345	5705		345	6624	
359		5617	359	5935		359	6890	
372		5834	372	6165		372	7157	
386		6051	386	6394		386	7423	
400		6269	400	6624		400	7690	
414		6486	414	6854		414	7957	
427		6706	427	7087		427	8227	
441		6927	441	7320		441	8498	
455		7147	455	7552		455	8768	
469		7368	469	7785		469	9038	
483		7588	483	8018		483	9309	
496		7805	496	8247		496	9575	
510		8021	510	8476		510	9840	
524		8238	524	8705		524	10106	
538		8454	538	8934		538	10372	
552		8671	552	9163		552	10637	
565	8899	565	9403	565	10917			
579	9127	579	9644	579	11196			
593	9355	593	9885	593	11476			
607	9583	607	10126	607	11755			
621	9810	621	10367	621	12035			
634	10024	634	10592	634	12297			
648	10238	648	10818	648	12559			
662	10452	662	11044	662	12822			
676	10665	676	11270	676	13084			
689	10879	689	11496	689	13346			

For reference purposes only, please consult the calibration chart specific to your purchase or rental tool.



TORQUE

TX-16 Torque Conversion Chart (Imperial)

	Imperial Conversion			Imperial Conversion			Imperial Conversion	
	PSI	Ft-lbs		PSI	Ft-lbs		PSI	Ft-lbs
	Hex Range 2 3/16" - 3 15/16"	1,000		1627	Hex Range 4" - 4 11/16"		1,000	1773
1,200		1931	1,200	2104		1,200	2462	
1,400		2234	1,400	2435		1,400	2849	
1,600		2538	1,600	2765		1,600	3236	
1,800		2842	1,800	3096		1,800	3623	
2,000		3145	2,000	3427		2,000	4011	
2,200		3448	2,200	3757		2,200	4397	
2,400		3752	2,400	4088		2,400	4784	
2,600		4055	2,600	4418		2,600	5170	
2,800		4358	2,800	4749		2,800	5557	
3,000		4661	3,000	5079		3,000	5944	
3,200		4965	3,200	5410		3,200	6331	
3,400		5269	3,400	5741		3,400	6719	
3,600		5573	3,600	6072		3,600	7106	
3,800		5876	3,800	6403		3,800	7493	
4,000		6180	4,000	6734		4,000	7881	
4,200		6483	4,200	7063		4,200	8266	
4,400		6785	4,400	7393		4,400	8652	
4,600		7087	4,600	7722		4,600	9037	
4,800		7389	4,800	8052		4,800	9423	
5,000		7692	5,000	8381		5,000	9808	
5,200		8001	5,200	8718		5,200	10203	
5,400		8311	5,400	9055		5,400	10597	
5,600		8620	5,600	9393		5,600	10992	
5,800		8930	5,800	9730		5,800	11387	
6,000		9239	6,000	10067		6,000	11781	
6,200		9553	6,200	10409		6,200	12181	
6,400		9866	6,400	10751		6,400	12581	
6,600		10180	6,600	11092		6,600	12981	
6,800		10494	6,800	11434		6,800	13381	
7,000		10808	7,000	11776		7,000	13781	
7,200		11111	7,200	12107		7,200	14168	
7,400		11415	7,400	12438		7,400	14556	
7,600	11719	7,600	12769	7,600	14943			
7,800	12023	7,800	13100	7,800	15331			
8,000	12326	8,000	13431	8,000	15718			
8,200	12646	8,200	13780	8,200	16126			
8,400	12966	8,400	14128	8,400	16534			
8,600	13286	8,600	14477	8,600	16942			
8,800	13606	8,800	14825	8,800	17350			
9,000	13926	9,000	15174	9,000	17758			
9,200	14245	9,200	15521	9,200	18164			
9,400	14563	9,400	15868	9,400	18570			
9,600	14881	9,600	16215	9,600	18976			
9,800	15200	9,800	16562	9,800	19382			
10,000	15518	10,000	16909	10,000	19788			

For reference purposes only, please consult the calibration chart specific to your purchase or rental tool.



TORCUP

TX-16 Torque Conversion Chart (Metric)

	Metric Conversion			Metric Conversion			Metric Conversion	
	Bar	Nm		Bar	Nm		Bar	Nm
	Hex Range 55-100mm	69		2206	Hex Range 101-117mm		69	2404
83		2618	83	2852		83	3338	
97		3029	97	3301		97	3863	
110		3441	110	3749		110	4388	
124		3853	124	4198		124	4913	
138		4264	138	4646		138	5438	
152		4675	152	5094		152	5962	
165		5087	165	5542		165	6486	
179		5498	179	5990		179	7010	
193		5909	193	6438		193	7534	
207		6320	207	6886		207	8059	
221		6732	221	7335		221	8584	
234		7144	234	7784		234	9109	
248		7555	248	8233		248	9634	
262		7967	262	8681		262	10159	
276		8379	276	9130		276	10685	
290		8789	290	9577		290	11207	
303		9199	303	10023		303	11730	
317		9609	317	10470		317	12253	
331		10019	331	10917		331	12775	
345		10429	345	11363		345	13298	
359		10848	359	11820		359	13833	
372		11268	372	12277		372	14368	
386		11687	386	12735		386	14903	
400		12107	400	13192		400	15438	
414		12527	414	13649		414	15973	
427		12952	427	14112		427	16515	
441		13377	441	14576		441	17058	
455		13802	455	15039		455	17600	
469		14228	469	15503		469	18142	
483		14653	483	15966		483	18685	
496		15065	496	16415		496	19210	
510		15477	510	16864		510	19735	
524		15889	524	17312		524	20260	
538		16301	538	17761		538	20785	
552		16712	552	18210		552	21311	
565	17146	565	18683	565	21864			
579	17580	579	19155	579	22417			
593	18014	593	19628	593	22970			
607	18447	607	20101	607	23523			
621	18881	621	20573	621	24076			
634	19313	634	21044	634	24627			
648	19745	648	21514	648	25177			
662	20177	662	21985	662	25728			
676	20608	676	22455	676	26278			
689	21040	689	22926	689	26829			

For reference purposes only, please consult the calibration chart specific to your purchase or rental tool.



TORQUE

TX-32 Torque Conversion Chart (Imperial)

Hex Range 3 1/8" - 4 5/8"	Imperial Conversion		Hex Range 4 11/16" - 6 1/2"	Imperial Conversion		Hex Range 6 9/16" - 7 7/8"	Imperial Conversion	
	PSI	Ft-lbs		PSI	Ft-lbs		PSI	Ft-lbs
	1,000	3472		1,000	3844		1,000	4340
1,200	4132	1,200	4574	1,200	5165			
1,400	4791	1,400	5305	1,400	5989			
1,600	5451	1,600	6035	1,600	6814			
1,800	6111	1,800	6766	1,800	7639			
2,000	6771	2,000	7496	2,000	8463			
2,200	7422	2,200	8217	2,200	9277			
2,400	8073	2,400	8938	2,400	10091			
2,600	8724	2,600	9658	2,600	10905			
2,800	9375	2,800	10379	2,800	11718			
3,000	10026	3,000	11100	3,000	12532			
3,200	10684	3,200	11829	3,200	13355			
3,400	11342	3,400	12558	3,400	14178			
3,600	12001	3,600	13286	3,600	15001			
3,800	12659	3,800	14015	3,800	15824			
4,000	13317	4,000	14744	4,000	16646			
4,200	13967	4,200	15464	4,200	17459			
4,400	14618	4,400	16184	4,400	18272			
4,600	15268	4,600	16904	4,600	19085			
4,800	15918	4,800	17624	4,800	19898			
5,000	16569	5,000	18344	5,000	20711			
5,200	17222	5,200	19068	5,200	21528			
5,400	17876	5,400	19791	5,400	22345			
5,600	18529	5,600	20515	5,600	23162			
5,800	19183	5,800	21238	5,800	23979			
6,000	19837	6,000	21962	6,000	24796			
6,200	20497	6,200	22693	6,200	25621			
6,400	21157	6,400	23424	6,400	26446			
6,600	21817	6,600	24154	6,600	27271			
6,800	22477	6,800	24885	6,800	28096			
7,000	23137	7,000	25616	7,000	28921			
7,200	23786	7,200	26334	7,200	29732			
7,400	24435	7,400	27053	7,400	30543			
7,600	25084	7,600	27771	7,600	31355			
7,800	25733	7,800	28490	7,800	32166			
8,000	26381	8,000	29208	8,000	32977			
8,200	27032	8,200	29928	8,200	33790			
8,400	27683	8,400	30649	8,400	34603			
8,600	28333	8,600	31369	8,600	35417			
8,800	28984	8,800	32090	8,800	36230			
9,000	29635	9,000	32810	9,000	37044			
9,200	30287	9,200	33532	9,200	37859			
9,400	30940	9,400	34255	9,400	38675			
9,600	31592	9,600	34977	9,600	39490			
9,800	32245	9,800	35700	9,800	40306			
10,000	32897	10,000	36422	10,000	41122			

For reference purposes only, please consult the calibration chart specific to your purchase or rental tool.



TORQUE

TX-32 Torque Conversion Chart (Metric)

	Metric Conversion			Metric Conversion			Metric Conversion	
	Bar	Nm		Bar	Nm		Bar	Nm
	Hex Range 80-119mm	69		4707	Hex Range 120-165mm		69	5212
83		5602	83	6202		83	7002	
97		6496	97	7192		97	8120	
110		7391	110	8183		110	9238	
124		8285	124	9173		124	10357	
138		9180	138	10163		138	11475	
152		10062	152	11140		152	12578	
165		10945	165	12118		165	13681	
179		11828	179	13095		179	14785	
193		12710	193	14072		193	15888	
207		13593	207	15050		207	16991	
221		14486	221	16038		221	18107	
234		15378	234	17026		234	19223	
248		16271	248	18014		248	20338	
262		17163	262	19002		262	21454	
276		18056	276	19990		276	22570	
290		18937	290	20966		290	23672	
303		19819	303	21943		303	24774	
317		20701	317	22919		317	25876	
331		21583	331	23895		331	26978	
345		22464	345	24871		345	28080	
359		23350	359	25852		359	29188	
372		24236	372	26833		372	30296	
386		25123	386	27814		386	31403	
400		26009	400	28795		400	32511	
414		26895	414	29776		414	33619	
427		27790	427	30767		427	34737	
441		28685	441	31758		441	35856	
455		29580	455	32749		455	36975	
469		30475	469	33740		469	38093	
483		31370	483	34731		483	39212	
496		32249	496	35705		496	40312	
510		33129	510	36679		510	41411	
524		34009	524	37653		524	42511	
538		34889	538	38627		538	43611	
552		35768	552	39601		552	44711	
565		36651	565	40577		565	45813	
579		37533	579	41554		579	46916	
593		38415	593	42531		593	48019	
607		39297	607	43508		607	49122	
621		40179	621	44484		621	50224	
634		41064	634	45464		634	51330	
648	41949	648	46443	648	52436			
662	42833	662	47423	662	53542			
676	43718	676	48402	676	54648			
689	44603	689	49382	689	55753			

For reference purposes only, please consult the calibration chart specific to your purchase or rental tool.



TORQUE

TX-45 Torque Conversion Chart (Imperial)

	Imperial Conversion			Imperial Conversion			Imperial Conversion	
	PSI	Ft-lbs		PSI	Ft-lbs		PSI	Ft-lbs
	Hex Range 3 1/8" - 4 5/8"	1,000		4543	Hex Range 4 11/16" - 6 1/2"		1,000	5030
1,200		5460	1,200	6045		1,200	6825	
1,400		6377	1,400	7061		1,400	7972	
1,600		7295	1,600	8076		1,600	9118	
1,800		8212	1,800	9092		1,800	10265	
2,000		9129	2,000	10107		2,000	11411	
2,200		10023	2,200	11097		2,200	12529	
2,400		10918	2,400	12088		2,400	13648	
2,600		11813	2,600	13078		2,600	14766	
2,800		12707	2,800	14069		2,800	15884	
3,000		13602	3,000	15059		3,000	17002	
3,200		14506	3,200	16061		3,200	18133	
3,400		15411	3,400	17062		3,400	19264	
3,600		16316	3,600	18064		3,600	20395	
3,800		17220	3,800	19065		3,800	21525	
4,000		18125	4,000	20067		4,000	22656	
4,200		19026	4,200	21064		4,200	23782	
4,400		19926	4,400	22061		4,400	24908	
4,600		20827	4,600	23058		4,600	26033	
4,800		21727	4,800	24055		4,800	27159	
5,000		22628	5,000	25052		5,000	28285	
5,200		23528	5,200	26049		5,200	29410	
5,400		24429	5,400	27046		5,400	30536	
5,600		25330	5,600	28044		5,600	31662	
5,800		26230	5,800	29041		5,800	32788	
6,000		27131	6,000	30038		6,000	33914	
6,200		28033	6,200	31037		6,200	35041	
6,400		28935	6,400	32035		6,400	36169	
6,600		29837	6,600	33034		6,600	37296	
6,800		30739	6,800	34032		6,800	38424	
7,000	31641	7,000	35031	7,000	39551			
7,200	32542	7,200	36029	7,200	40677			
7,400	33443	7,400	37026	7,400	41804			
7,600	34344	7,600	38024	7,600	42930			
7,800	35245	7,800	39021	7,800	44056			
8,000	36146	8,000	40019	8,000	45183			
8,200	37047	8,200	41017	8,200	46309			
8,400	37949	8,400	42015	8,400	47436			
8,600	38850	8,600	43012	8,600	48562			
8,800	39751	8,800	44010	8,800	49689			
9,000	40652	9,000	45008	9,000	50815			
9,200	41553	9,200	46005	9,200	51941			
9,400	42453	9,400	47002	9,400	53067			
9,600	43354	9,600	47999	9,600	54192			
9,800	44254	9,800	48996	9,800	55318			
10,000	45155	10,000	49993	10,000	56444			

For reference purposes only, please consult the calibration chart specific to your purchase or rental tool.



TORCUP

TX-45 Torque Conversion Chart (Metric)

	Metric Conversion			Metric Conversion			Metric Conversion	
	Bar	Nm		Bar	Nm		Bar	Nm
	Hex Range 80-119mm	69		6160	Hex Range 120-165mm		69	6820
83		7403	83	8196		83	9254	
97		8647	97	9573		97	10808	
110		9890	110	10950		110	12363	
124		11134	124	12327		124	13917	
138		12377	138	13703		138	15471	
152		13590	152	15046		152	16987	
165		14803	165	16389		165	18504	
179		16016	179	17732		179	20020	
193		17229	193	19074		193	21536	
207		18441	207	20417		207	23052	
221		19668	221	21775		221	24585	
234		20895	234	23133		234	26118	
248		22121	248	24491		248	27651	
262		23348	262	25849		262	29185	
276		24574	276	27207		276	30718	
290		25795	290	28559		290	32244	
303		27016	303	29911		303	33770	
317		28237	317	31262		317	35296	
331		29458	331	32614		331	36822	
345		30679	345	33966		345	38349	
359		31900	359	35318		359	39875	
372		33121	372	36670		372	41402	
386		34342	386	38022		386	42928	
400		35564	400	39374		400	44455	
414		36785	414	40726		414	45981	
427		38008	427	42080		427	47510	
441		39231	441	43434		441	49038	
455		40454	455	44788		455	50567	
469		41676	469	46142		469	52096	
483		42899	483	47496		483	53624	
496		44121	496	48848		496	55151	
510		45343	510	50201		510	56678	
524		46564	524	51553		524	58205	
538		47786	538	52906		538	59732	
552		49008	552	54258		552	61260	
565	50230	565	55611	565	62787			
579	51451	579	56964	579	64314			
593	52673	593	58317	593	65842			
607	53895	607	59670	607	67369			
621	55117	621	61023	621	68897			
634	56338	634	62374	634	70423			
648	57559	648	63726	648	71949			
662	58780	662	65078	662	73475			
676	60001	676	66430	676	75001			
689	61222	689	67781	689	76527			

For reference purposes only, please consult the calibration chart specific to your purchase or rental tool.

TX-1 Series Cylinder

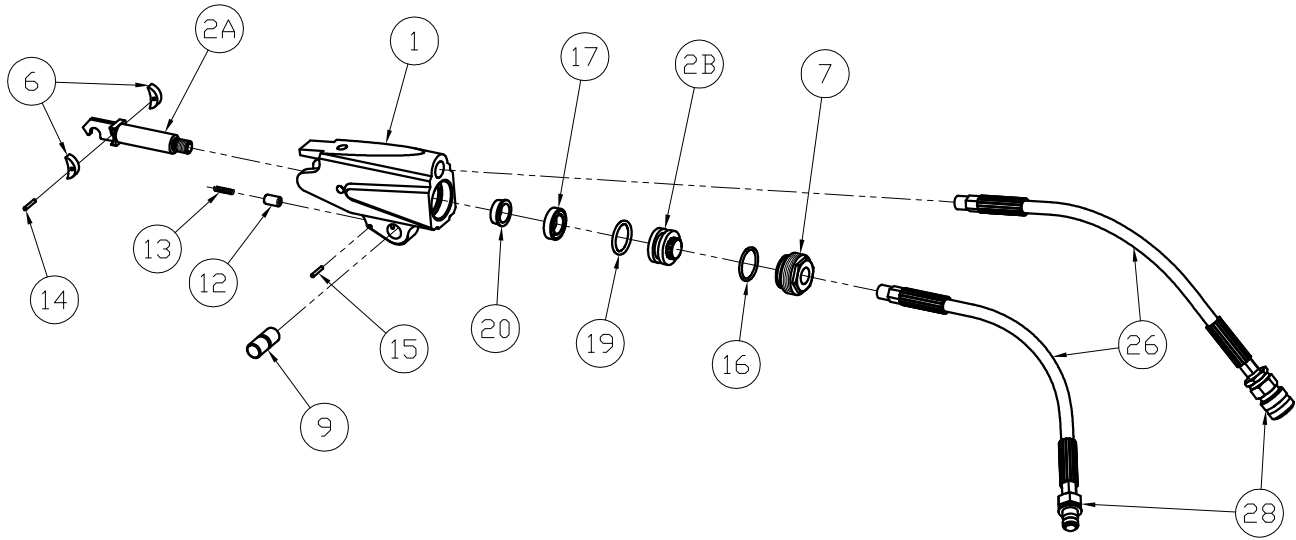

Part Numbers for Ordering

ITEM	NAME	PART #	QTY.
1	Housing	TX-1-C01	1
2A	Piston Rod	TX-1-C03-1	1
2B	Piston Cap	TX-1-C03-2	1
6	Slider	TX-1-C09	2
7	End Cap	TX-1-C11	1
9	Link Pin	TX-1-C15	1
12	Plunger	TX-1-C25	1
13	Plunger Spring	TX-1-C26	1
14	Slider Pin	TX-1-C27	1
15	Plunger Pin	TX-1-C28	1
16	End Plug Seal	TX-1-C29	1
17	Rod Seal	TX-1-C31	1
19	Piston Seal	TX-1-C33	1
20	Rod Bushing	TX-1-C51	1
26	Whip Hose - 16"	HPH-16"-1/8	2
28	Coupler Set	HC-S-100	1
	Piston Assembly (2A & 2B)	TX-1-C03	

TX-1 Series Link

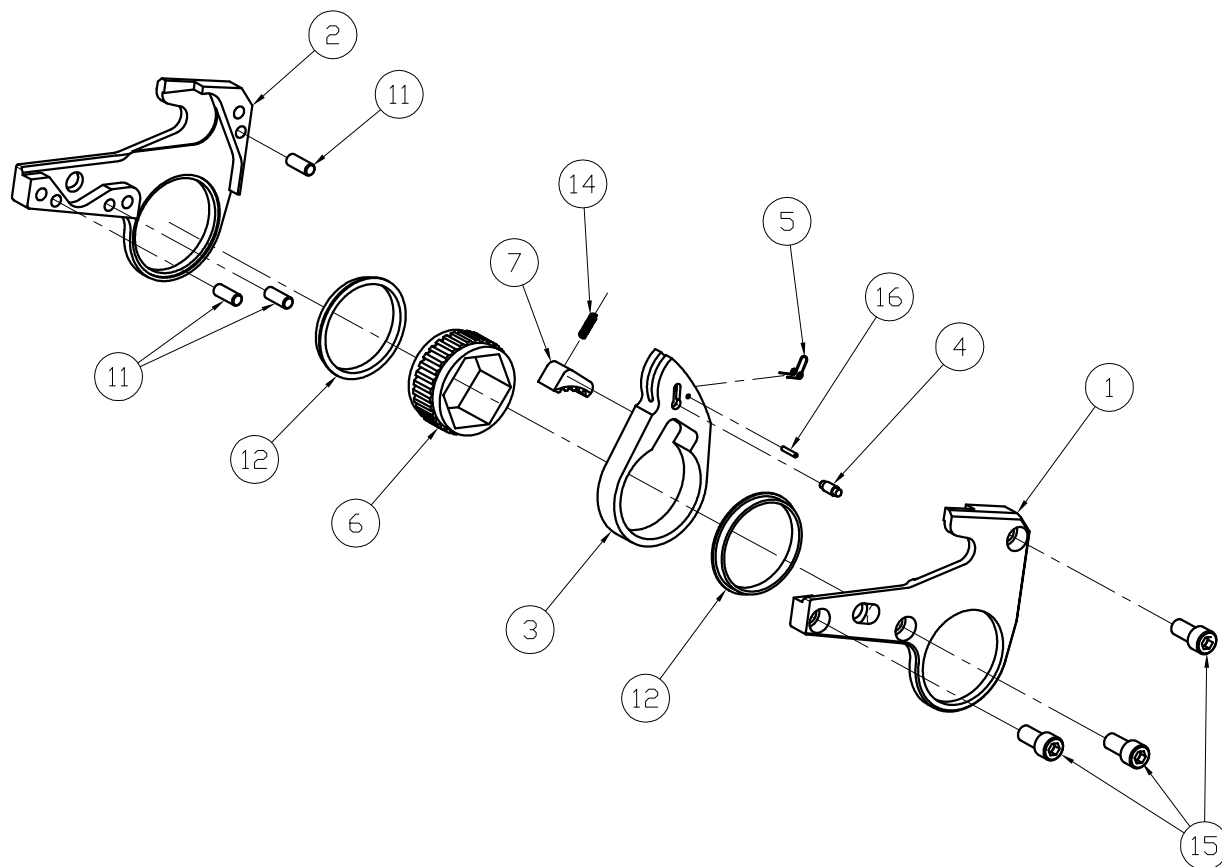

Part Numbers for Ordering

ITEM	NAME	PART #	QTY.
1	Side Plate - Left	TX-1-L01- #*	1
2	Side Plate - Right	TX-1-L02- #*	1
3	Drive Plate	TX-1-L03- #*	1
4	Drive Pin	TX-1-L05	1
5	Drive Pin Spring	TX-1-L07	1
6	Ratchet	TX-1-L09- #*	1
7	Drive Segment	TX-1-L11- #*	1
11	Spacer Pin	TX-1-L17	3
12	Sideplate Sleeves	TX-1-L19- #*	2
14	Segment Spring	TX-1-L25	1
15	Side Plate Screws	TX-1-L29	3
16	Dr. Pin Spring Roll Pin	TX-1-L33	1

*part number is dependent upon ratchet link size

TX-2 Series Cylinder

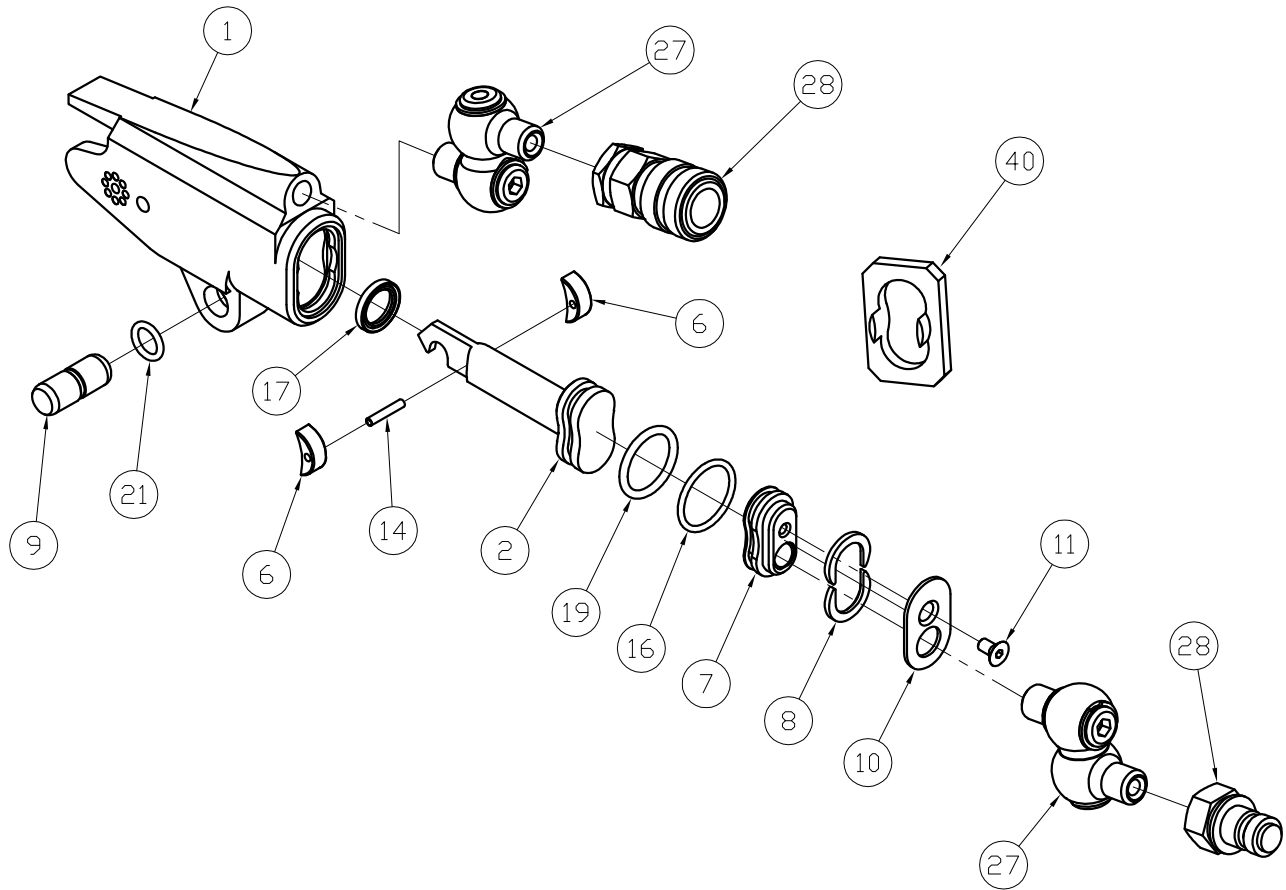

Part Numbers for Ordering

ITEM	NAME	PART #	QTY.
1	Housing	TX-2-C01	1
2	Piston	TX-2-C03	1
6	Slider	TX-2-C09	2
7	End Cap	TX-2-C11	1
8	Retaining Ring	TX-2-C13	2
9	Link Pin	TX-2-C15	1
10	End Cover	TX-2-C17	1
11	End Cover Screw	TX-2-C23	1
14	Slider Pin	TX-2-C27	1
16	End Plug Seal	TX-2-C29	1
17	Rod Seal	TX-2-C31	1
19	Piston Seal	TX-2-C33	1
21	Link Retaining Spring	TX-2-C53	1
27	Swivel Assembly	STX-8M-4M	2
28	Coupler Set	HC-S-100	1
40	Seal Insertion Tool	ATX-2-ST	

TX-2 Series Link

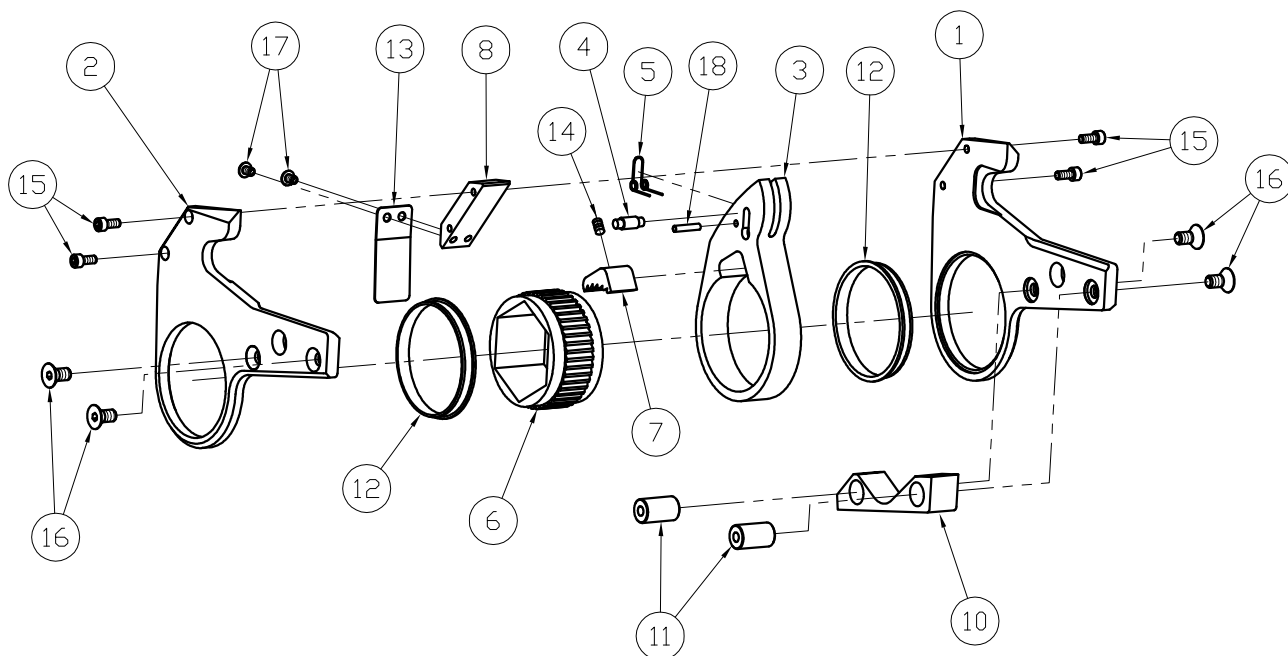

Part Numbers for Ordering

ITEM	NAME	PART #	QTY.
1	Side Plate - Left	TX-2-L01- #*	1
2	Side Plate - Right	TX-2-L02- #*	1
3	Drive Plate	TX-2-L03- #*	1
4	Drive Pin	TX-2-L05	1
5	Drive Pin Spring	TX-2-L07	1
6	Ratchet	TX-2-L09- #*	1
7	Drive Segment	TX-2-L11- #*	1
8	Upper Spacer	TX-2-L13- #*	1
10	Lower Spacer	TX-2-L15- #*	1
11	Spacer Pin	TX-2-L17	2
12	Sideplate Sleeve	TX-2-L19- #*	2
13	Shroud	TX-2-L21	1
14	Segment Spring	TX-2-L25	1
15	Upper Spacer Screw	TX-2-L27	4
16	Lower Spacer Screw	TX-2-L29	4
17	Shroud Screw	TX-2-L31	2
18	Dr. Pin Spring Roll Pin	TX-2-L33	1

*part number is dependent upon ratchet link size

TX-4 Series Cylinder

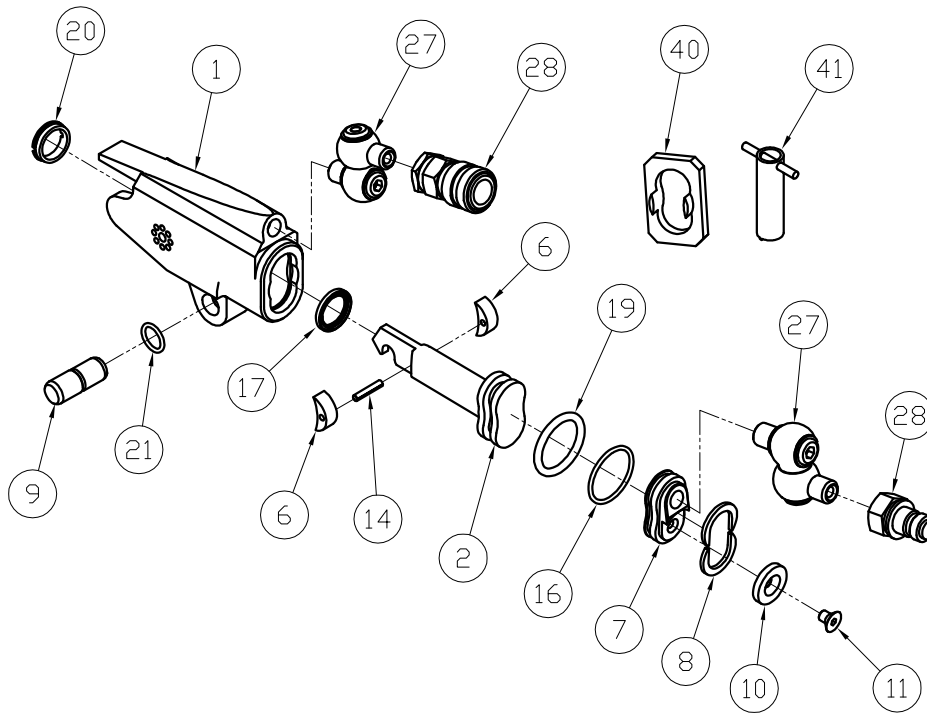

Part Numbers for Ordering

ITEM	NAME	PART #	QTY.
1	Housing	TX-4-C01	1
2	Piston	TX-4-C03	1
6	Slider	TX-4-C09	2
7	End Cap	TX-4-C11	1
8	Retaining Ring	TX-4-C13	2
9	Link Pin	TX-4-C15	1
10	End Cover	TX-4-C17	1
11	End Cover Screw	TX-4-C23	1
14	Slider Pin	TX-4-C27	1
16	End Plug Seal	TX-4-C29	1
17	Rod Seal	TX-4-C31	1
19	Piston Seal	TX-4-C33	1
20	Cylinder Gland	TX-4-C51	1
21	Link Retaining Spring	TX-4-C53	1
27	Swivel Assembly	STX-4M-4M	2
28	Coupler Set	HC-S-100	1
40	Seal Insertion Tool	ATX-4-ST	
41	Gland Removal Tool	ATX-4-GW	

TX-4 Series Link

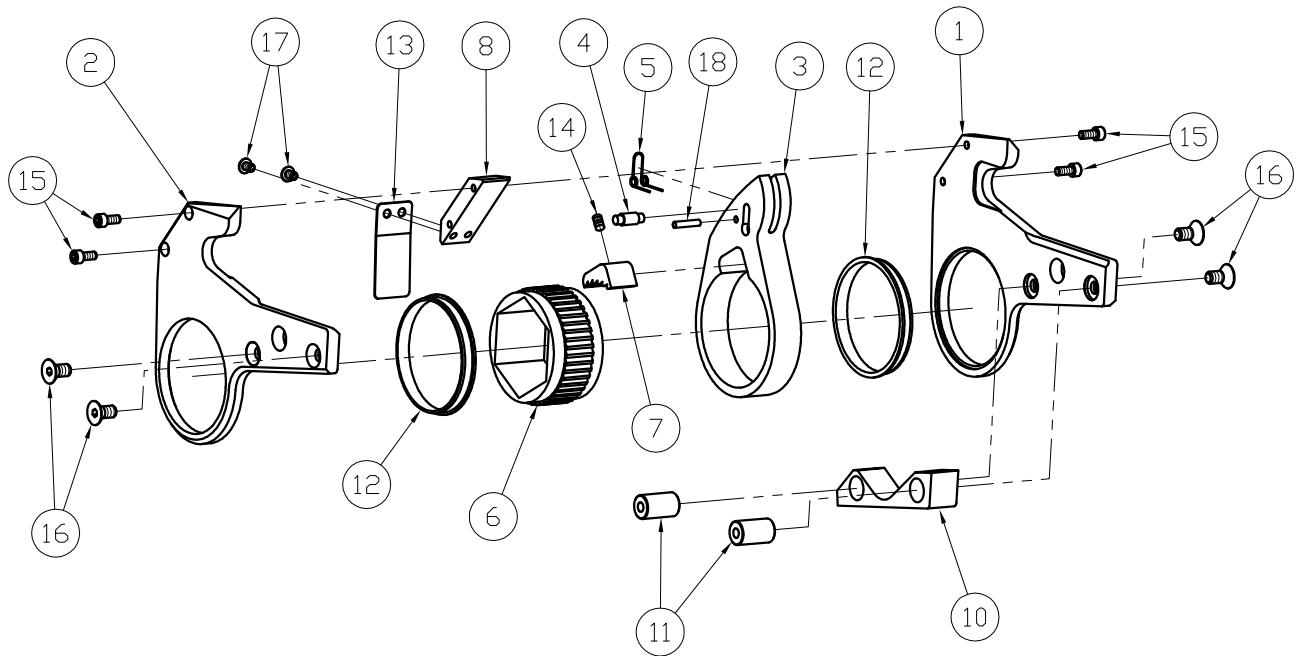

Part Numbers for Ordering

ITEM	NAME	PART #	QTY.
1	Side Plate - Left	TX-4-L01- #*	1
2	Side Plate - Right	TX-4-L02- #*	1
3	Drive Plate	TX-4-L03- #*	1
4	Drive Pin	TX-4-L05	1
5	Drive Pin Spring	TX-4-L07	1
6	Ratchet	TX-4-L09- #*	1
7	Drive Segment	TX-4-L11- #*	1
8	Upper Spacer	TX-4-L13- #*	1
10	Lower Spacer	TX-4-L15- #*	1
11	Spacer Pin	TX-4-L17	2
12	Sideplate Sleeve	TX-4-L19- #*	2
13	Shroud	TX-4-L21	1
14	Segment Spring	TX-4-L25	1
15	Upper Spacer Screw	TX-4-L27	4
16	Lower Spacer Screw	TX-4-L29	4
17	Shroud Screw	TX-4-L31	2
18	Dr. Pin Spring Roll Pin	TX-4-L33	1

*part number is dependent upon ratchet link size

TX-8 Series Cylinder

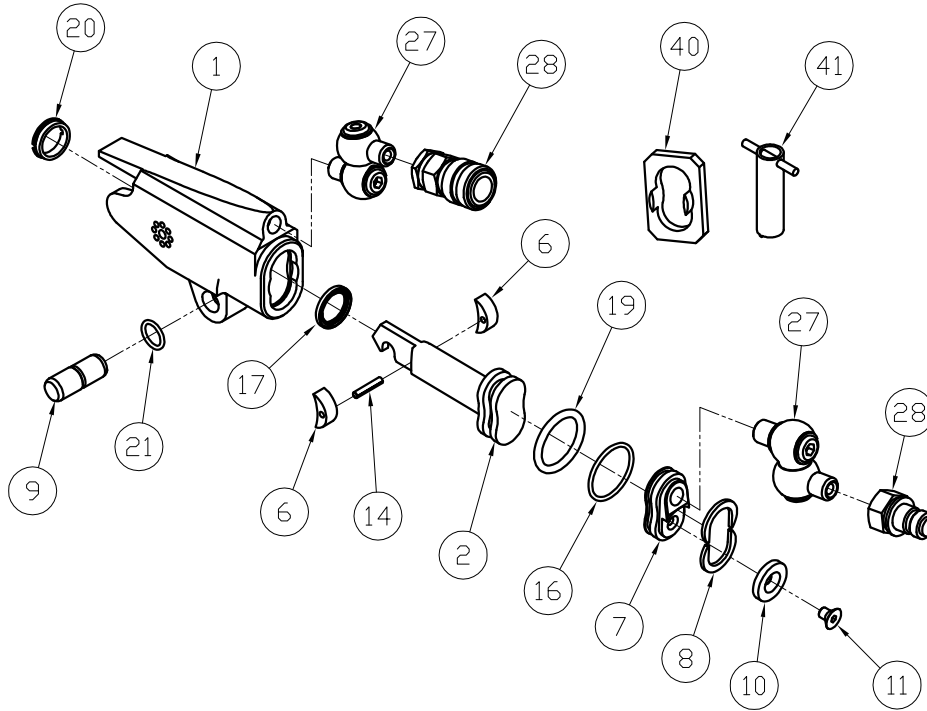

Part Numbers for Ordering

ITEM	NAME	PART #	QTY.
1	Housing	TX-8-C01	1
2	Piston	TX-8-C03	1
6	Slider	TX-8-C09	2
7	End Cap	TX-8-C11	1
8	Retaining Ring	TX-8-C13	2
9	Link Pin	TX-8-C15	1
10	End Cover	TX-8-C17	1
11	End Cover Screw	TX-8-C23	1
14	Slider Pin	TX-8-C27	1
16	End Plug Seal	TX-8-C29	1
17	Rod Seal	TX-8-C31	1
19	Piston Seal	TX-8-C33	1
20	Cylinder Gland	TX-8-C51	1
21	Link Retaining Spring	TX-8-C53	1
27	Swivel Assembly	STX-4M-4M	2
28	Coupler Set	HC-S-100	1
40	Seal Insertion Tool	ATX-8-ST	
41	Gland Removal Tool	ATX-8-GW	

TX-8 Series Link

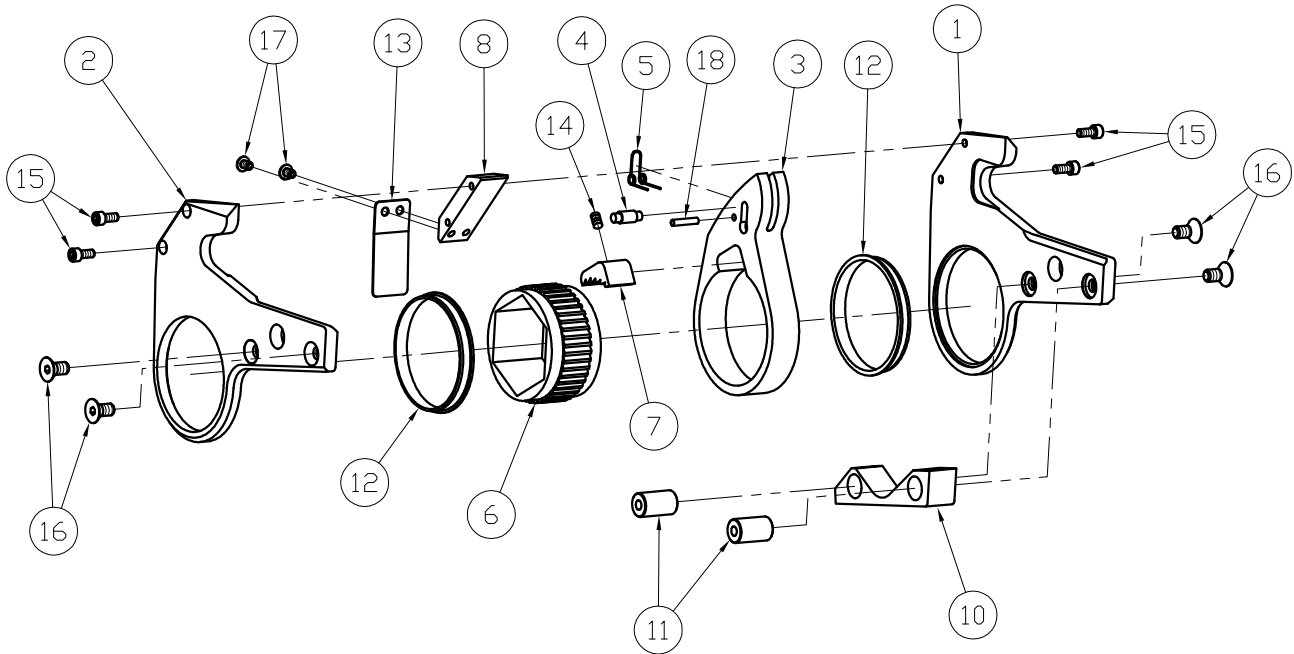

Part Numbers for Ordering

ITEM	NAME	PART #	QTY.
1	Side Plate - Left	TX-8-L01- #*	1
2	Side Plate - Right	TX-8-L02- #*	1
3	Drive Plate	TX-8-L03- #*	1
4	Drive Pin	TX-8-L05	1
5	Drive Pin Spring	TX-8-L07	1
6	Ratchet	TX-8-L09- #*	1
7	Drive Segment	TX-8-L11- #*	1
8	Upper Spacer	TX-8-L13- #*	1
10	Lower Spacer	TX-8-L15- #*	1
11	Spacer Pin	TX-8-L17	2
12	Sideplate Sleeve	TX-8-L19- #*	2
13	Shroud	TX-8-L21- #*	1
14	Segment Spring	TX-8-L25	1
15	Upper Spacer Screw	TX-8-L27	4
16	Lower Spacer Screw	TX-8-L29	4
17	Shroud Screw	TX-8-L31	2
18	Dr. Pin Spring Roll Pin	TX-8-L33	1

*part number is dependent upon ratchet link size

TX-16 Series Cylinder

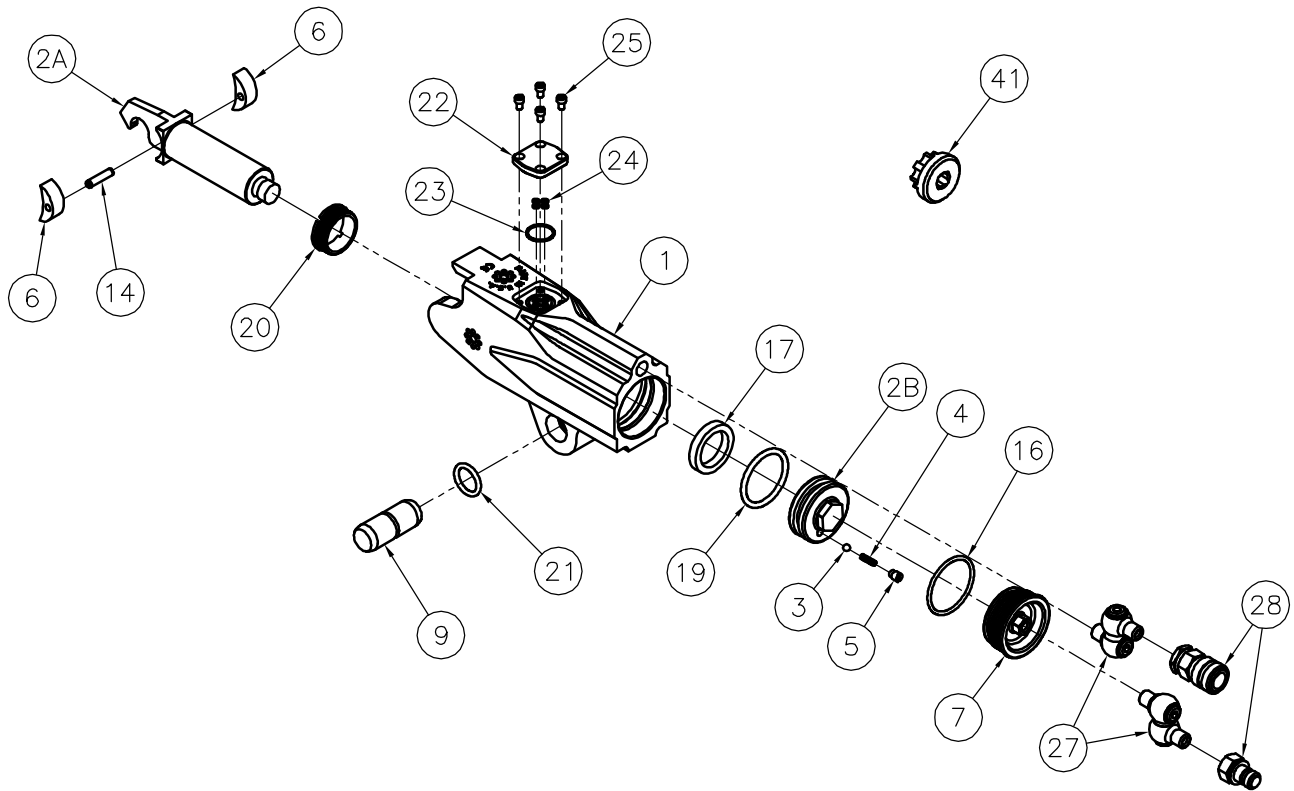

Part Numbers for Ordering

ITEM NAME	PART #	QTY.	ITEM NAME	PART #	QTY.
1 Housing	TX-16-C01	1	19 Piston Seal	TX-16-C33	1
2A Piston Rod	TX-16-C03-1	1	20 Cylinder Gland	TX-16-C51	1
2B Piston Cap	TX-16-C03-2	1	21 Link Retaining Spring	TX-16-C53	1
3 Valve Ball	TX-16-C03-3	1	22 Seal Plate	TXU-16-C54	1
4 Valve Spring	TX-16-C03-4	1	23 O-ring (Large)	USL-11	1
5 Valve Cup	TX-16-C03-5	1	24 O-ring (Small)	USL-13	4
6 Slider	TX-16-C09	2	25 Seal Plate Screw	USL-23	4
7 End Cap	TX-16-C11	1	27 Swivel Assembly	STX-4M-4M	2
9 Link Pin	TX-16-C15	1	28 Coupler Set	HC-S-100	1
14 Slider Pin	TX-16-C27	1	41 Gland Removal Tool	ATX-16-GW	
16 End Plug Seal	TX-16-C29	1			
17 Rod Seal	TX-16-C31	1	Piston Assembly (2A, 2B, 3, 4, 5)	TX-16-C03	

TX-16 Series Link

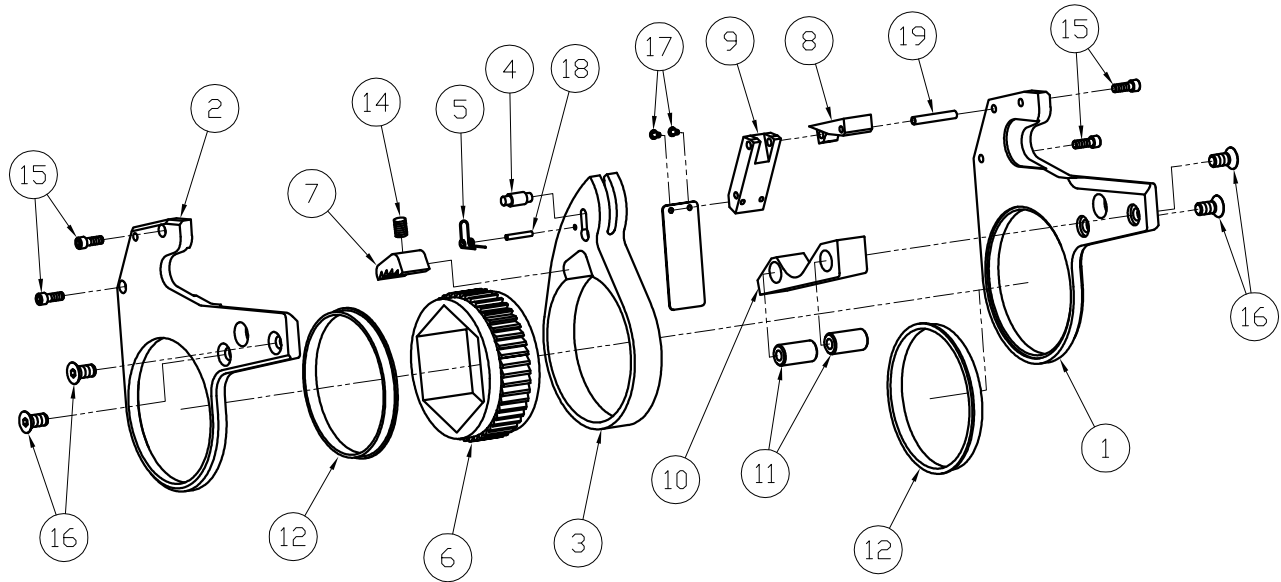

Part Numbers for Ordering

ITEM	NAME	PART #	QTY.
1	Side Plate - Left	TX-16-L01- #*	1
2	Side Plate - Right	TX-16-L02- #*	1
3	Drive Plate	TX-16-L03- #*	1
4	Drive Pin	TX-16-L05	1
5	Drive Pin Spring	TX-16-L07	1
6	Ratchet	TX-16-L09- #*	1
7	Drive Segment	TX-16-L11- #*	1
8	Upper Spacer	TX-16-L13	1
9	Middle Spacer	TX-16-L14- #*	1
10	Lower Spacer	TX-16-L15- #*	1
11	Spacer Pin	TX-16-L17	2
12	Sideplate Sleeve	TX-16-L19- #*	2
13	Shroud	TX-16-L21	1
14	Segment Spring	TX-16-L25	1
15	Upper Spacer Screw	TX-16-L27	4
16	Lower Spacer Screw	TX-16-L29	4
17	Shroud Screw	TX-16-L31	2
18	Dr. Pin Spring Roll Pin	TX-16-L33	1
19	Spacer Roll Pin	TX-16-L35	1

*part number is dependent upon ratchet link size

TX-32 Series Cylinder

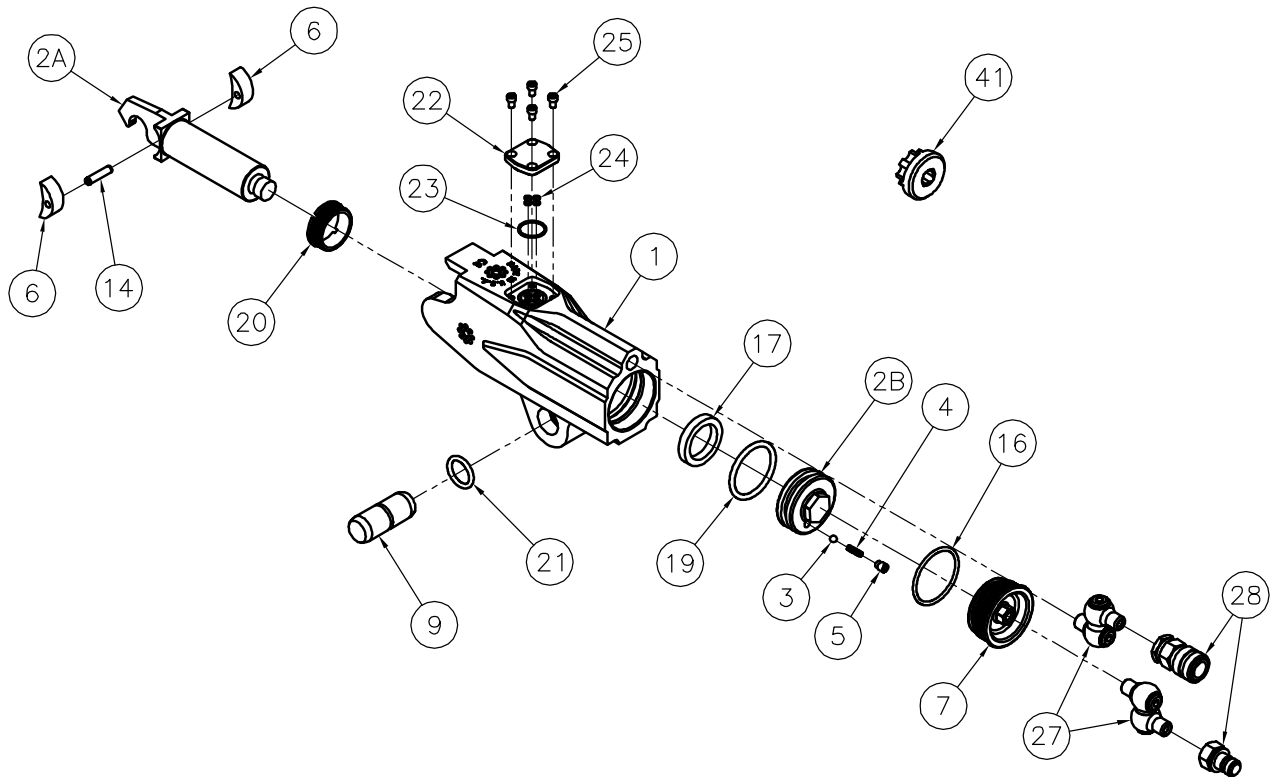

Part Numbers for Ordering

ITEM NAME	PART #	QTY.	ITEM NAME	PART #	QTY.
1 Housing	TX-32-C01	1	19 Piston Seal	TX-32-C33	1
2A Piston Rod	TX-32-C03-1	1	20 Cylinder Gland	TX-32-C51	1
2B Piston Cap	TX-32-C03-2	1	21 Link Retaining Spring	TX-32-C53	1
3 Valve Ball	TX-32-C03-3	1	22 Seal Plate	TXU-32-C54	1
4 Valve Spring	TX-32-C03-4	1	23 O-ring (Large)	USL-11	1
5 Valve Cup	TX-32-C03-5	1	24 O-ring (Small)	USL-13	4
6 Slider	TX-32-C09	2	25 Seal Plate Screw	USL-23	4
7 End Cap	TX-32-C11	1	27 Swivel Assembly	STX-4M-4M	2
9 Link Pin	TX-32-C15	1	28 Coupler Set	HC-S-100	1
14 Slider Pin	TX-32-C27	1	41 Gland Removal Tool	ATX-32-GW	
16 End Plug Seal	TX-32-C29	1			
17 Rod Seal	TX-32-C31	1	Piston Assembly (2A, 2B, 3, 4, 5)	TX-32-C03	

TX-32/45 Series Link

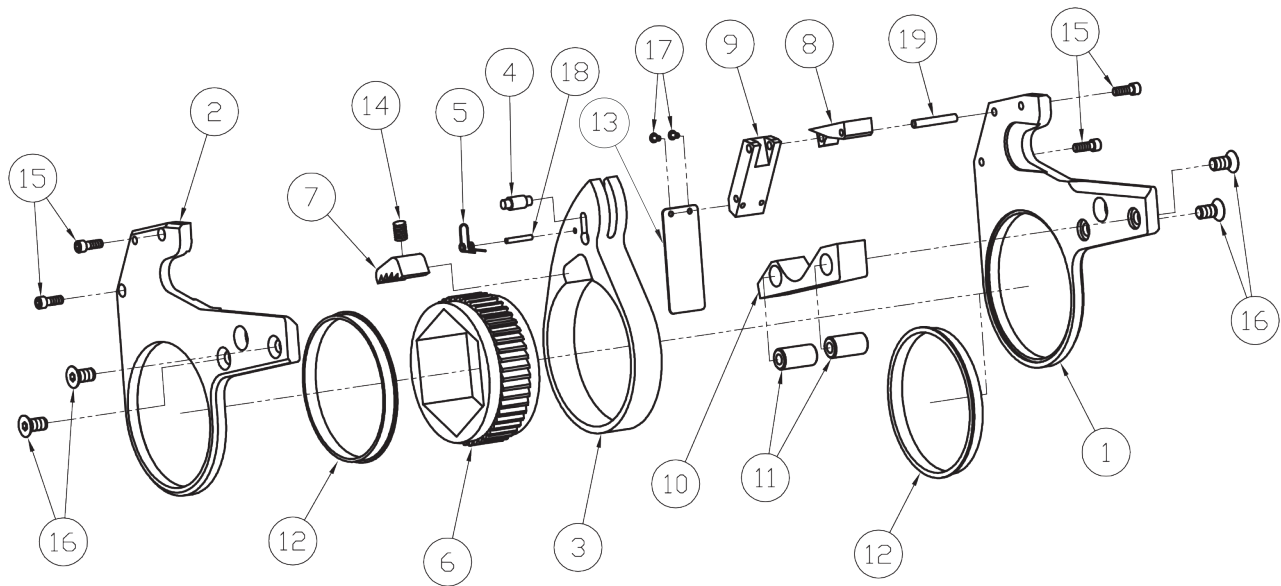

Part Numbers for Ordering

ITEM	NAME	PART #	QTY.
1	Side Plate - Left	TX-32-L01- #*	1
2	Side Plate - Right	TX-32-L02- #*	1
3	Drive Plate	TX-32-L03- #*	1
4	Drive Pin	TX-32-L05	1
5	Drive Pin Spring	TX-32-L07	1
6	Ratchet	TX-32-L09- #*	1
7	Drive Segment	TX-32-L11- #*	1
8	Upper Spacer	TX-32-L13	1
9	Middle Spacer	TX-32-L14- #*	1
10	Lower Spacer	TX-32-L15- #*	1
11	Spacer Pin	TX-32-L17	2
12	Sideplate Sleeve	TX-32-L19- #*	2
13	Shroud	TX-32-L21	1
14	Segment Spring	TX-32-L25	1
15	Upper Spacer Screw	TX-32-L27	4
16	Lower Spacer Screw	TX-32-L29	4
17	Shroud Screw	TX-32-L31	2
18	Dr. Pin Spring Roll Pin	TX-32-L33	1
19	Spacer Roll Pin	TX-32-L35	1

*part number is dependent upon ratchet link size

TX-45 Series Cylinder

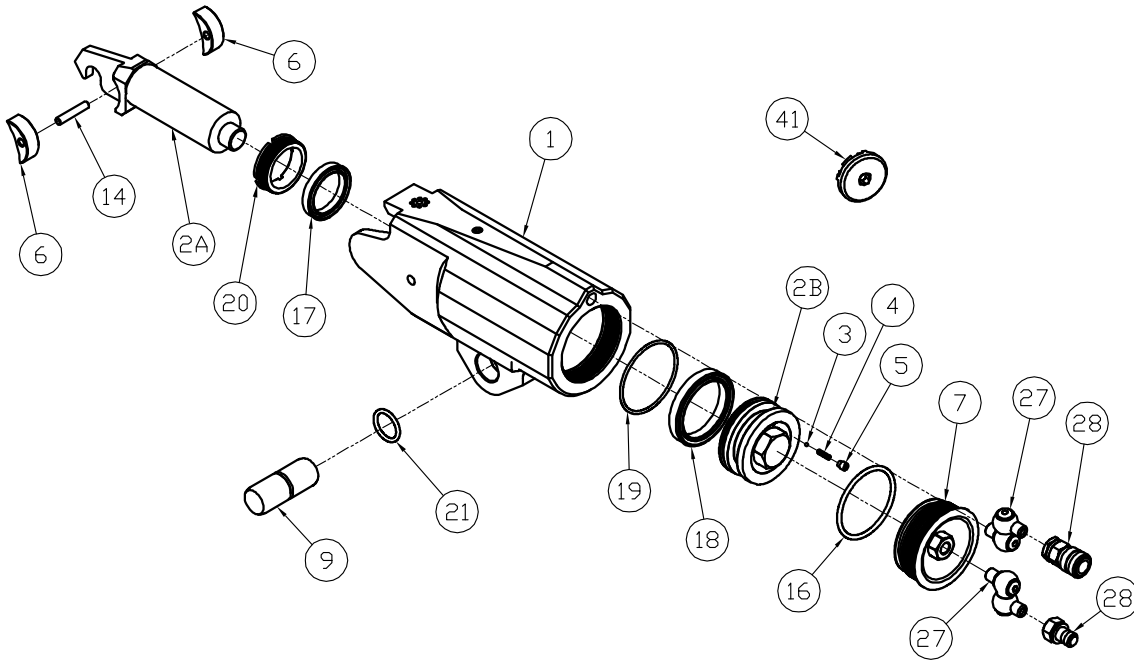

Part Numbers for Ordering

ITEM	NAME	PART #	QTY.
1	Housing	TX-45-C01	1
2A	Piston Rod	TX-45-C03-1	1
2B	Piston Cap	TX-45-C03-2	1
3	Valve Ball	TX-45-C03-3	1
4	Valve Spring	TX-45-C03-4	1
5	Valve Cup	TX-45-C03-5	1
6	Slider	TX-45-C09	2
7	End Cap	TX-45-C11	1
9	Link Pin	TX-45-C15	1
14	Slider Pin	TX-45-C27	1
16	End Plug Seal	TX-45-C29	1
17	Rod Seal	TX-45-C31	1
18	Piston Cup Seal	TX-45-C32	1
19	Piston Seal	TX-45-C33	1
20	Rod Bushing	TX-45-C51	1
21	Link Retaining Spring	TX-45-C53	1
27	Swivel Assembly	STX-4M-4M	2
28	Coupler Set	HC-S-100	1
41	Gland Removal Tool	ATX-45-GW	
	Piston Assembly (2A, 2B, 3, 4, 5)	TX-45-C03	

MAINTENANCE SECTION

WARNING

Always turn off the power supply. Bleed off hydraulic fluid from the hose connections on the cylinder assembly and disconnect the hoses before attempting to repair or perform maintenance on this tool. Always wear eye protection when operating or performing maintenance on this tool.

DISASSEMBLY

GENERAL INSTRUCTIONS

1. Do not disassemble the tool any further than necessary to replace or repair damaged parts.
2. Use extra care not to score, nick or damage surfaces that will contain hydraulic oil under pressure.
3. Whenever grasping a tool in a vise, always use leather-covered or copper-covered vise jaws to protect the surface of the part and help prevent distortion. This is particularly true of threaded members and housings.
4. Do not remove any part that is press fit in or on an assembly unless the removal of that part is necessary for repairs or replacement.
5. Do not disassemble the hydraulic cylinder assembly unless you have a complete set of seals and O-rings for replacement.
6. Use only British Standard fractional size tools when disassembling these tools.

DISASSEMBLY OF THE TOOL

1. Push the link pin (9) out of the housing (1) and side plates (1 & 2).
2. Lift the housing from between the side plates and separate the two units.

DISASSEMBLY OF THE TX-1 CYLINDER ASSEMBLIES

1. Clamp the housing in copper-covered or leather-covered vise jaws with the inlet end upward, using a wrench, unscrew and remove the two whip hoses (26) with their attached couplers (28).
2. Remove the housing assembly from the vise jaws and turn over a container to catch any oil remaining inside the cylinder.
3. Re-clamp the housing in the vise with the inlet end upward.
4. Using a wrench on the hex of the end plug wrench, unscrew and remove the end cap (7) with the end plug seal (16).
5. Using a socket on the hex of the piston cap (2B), unscrew and remove the piston cap from the piston rod (2A).
6. Remove the housing from the vise and turn over a container to empty any remaining oil from the housing.
7. Re-clamp the housing in the vise and remove the piston rod (2A) from the housing. If necessary, tap the threaded end of the piston rod with a brass tap being careful not to damage the threads.
8. Press the brass bushing (20), from the piston rod end of the housing, out of the housing.
9. To remove the sliders (6), position the slider pin (14) over a clearance opening in a soft block and use a small drift to tap the pin out of the sliders and the piston rod.

MAINTENANCE SECTION

DISASSEMBLY OF THE TX-2, TX-4, AND TX-8 CYLINDER ASSEMBLIES

1. Place the tool with the slider pin hole over a clearance opening and use a small drift to tap the slider pin (14) out of the sliders (6) and piston (2).
2. Clamp the housing in copper-covered or leather-covered vise jaws with the inlet end upward, using a 1/4" hex wrench, unscrew and remove the two swivel assemblies (27) with their attached couplers (28).
3. Remove the housing assembly from the vise jaws and turn over a container to catch any oil remaining inside the cylinder.
4. Re-clamp the housing in the vise with the inlet end upward.
5. Use a hex wrench to unscrew and remove the end cover screw (11). Remove the end cover (10).
6. Tap the end cap (7) inward approximately 1/2" and remove the two retaining rings (8) by working them out of the groove in the cylinder. **Note:** Covering the oil ports with a cloth will contain any oil that may expel from the housing.

CAUTION

The purpose of the seal insertion tool in the following step is to prevent the end plug seal from expanding into the retaining ring groove. If the tool is not used, place two thin pieces of flat stock at the midpoint of the opening against opposite walls to control the seal expansion.

7. Install the seal insertion tool (40) on the inlet end of the housing. **Note:** Lubricating the inside of the insertion tool will ease in the removal of the piston (2) and end cap (7).
8. Invert the tool above the vice. Place a cloth draped between the jaws of the vice to contain the exiting parts. Spread the vice open enough to catch the end plug and piston.
9. Tap the piston with a brass tap lightly until both the piston and end cap slip through the housing and into the catch cloth.
10. Use the gland removal tool (41) to unscrew and remove the cylinder gland (20) from the housing. **Note: The TX-2 does not have a cylinder gland.**

NOTICE

During removal and after the piston shaft is removed; **DO NOT** grasp the round portion of the shaft with any holding device that will damage the surface. Any nicks or scratches to the surface will allow hydraulic oil to leak from the cylinder when the tool is reassembled.

DISASSEMBLY OF THE TX-16, TX-32 AND TX-45 CYLINDER ASSEMBLIES

1. Clamp the housing in copper-covered or leather-covered vise jaws with the inlet end upward, using a 1/4" hex wrench, unscrew and remove the two swivel assemblies (27) with their attached couplers (28).
2. Remove the housing assembly from the vise jaws and turn over a container to catch any oil remaining inside the cylinder.
3. Re-clamp the housing in the vise with the inlet end upward.
4. Using a socket on the hex of the end cap (7), unscrew and remove the end cap with the end plug seal.
5. Using a socket on the hex of the piston cap (2B), unscrew and remove the piston cap from the piston rod (2A).
6. Remove the housing from the vise and turn over a container to empty any remaining oil from the housing.
7. Re-clamp the housing with the end plug end upward in the vise. Place a cloth between the jaws of the vice to contain the exiting parts. Gently tap the piston rod (2A) with a brass draft to remove it from the housing, being careful not to damage the threads.

MAINTENANCE SECTION

8. Reclamp the housing in the vice so that the cylinder gland (20) is visible.
9. Use the gland removal tool (41) to unscrew the cylinder gland (20) from the housing.
10. Place the slider pin in the piston rod over a clearance opening in a soft block. Use a small drift to tap the pin out of the sliders and piston rod.

NOTICE

Under normal circumstances, the seal plate will not need to be removed for maintenance.

TO REMOVE SEAL PLATE ON TX-16 AND TX-32

1. Unscrew seal plate screws. (25)
2. Remove seal plate (22).
3. Inspect o-rings (23 & 24), replace if needed.
4. Insert seal plate into hole in housing.
5. Use a thread locking compound on plate screws before fastening seal plate to housing.

DISASSEMBLY OF THE RATCHET LINK

1. Lay the ratchet link flat on a workbench with the left side plate (1) downward and using a hex wrench, unscrew and remove the two lower spacer screws (16). **Note: TX-1 ratchet links do not have Upper Spacers or Lower Spacers.**
2. Using a hex wrench, unscrew and remove the two upper spacer screws (15). **Note: TX-1 ratchet links do not have Upper Spacers or Lower Spacers.**
3. **For series TX-16, TX-32, and TX-45 models:** Use a roll pin punch to tap the spacer roll pin (19) out of the right side plate (2).
4. While applying thumb pressure to the edge of the ratchet (6), carefully lift the side plate off the assembly.
5. Grasp the ratchet and drive plate (3) and, while maintaining their relationship, lift them both off the left side plate.
6. Push the ratchet out of the drive plate and remove the drive segment (7) and the segment spring (14) from the drive plate recess.

NOTICE

When the ratchet is removed from the drive plate, the drive segment and segment spring will be free to fall from the drive plate recess. Do not allow the drive segment to fall on a hard surface that might chip the teeth.

7. If the drive pin (4) or drive pin spring (5) must be replaced, use a roll pin punch to push the drive pin spring roll pin (18) out of the drive plate. Once the pin spring is removed, the drive pin (4) will drop down to the large opening at the bottom of the slot for easy removal.
8. Lift the lower spacer (10) off the lower spacer pins (11). If the pins must be replaced, use a hex wrench to remove the two lower spacer screws from the right side plate. Pull the pins out of the holes on the inner face of the right side plate.
9. **For Series TX-2, TX-4, and TX-8 models:** Unscrew the two spacer screws and remove the upper spacer (8) from the right side plate. **For Series TX-16, TX-32, TX-45 models:** Use a roll pin punch to remove the spacer roll pin (19) from the right side plate. Unscrew the two spacer screws and remove the middle spacer (9) and upper spacer (8) from the right side plate.
10. If the side plate sleeves (12) must be replaced, press the sleeves out toward the inner face of the side plate. **Note: TX-1 ratchet links do not have Upper Spacers or Lower Spacers.**

MAINTENANCE SECTION

NOTICE

Inspect all parts prior to assembly. Replace any worn or damaged parts.

ASSEMBLY

ASSEMBLY OF TX-1 CYLINDER ASSEMBLIES

1. Press the slider pin (14) into one of the sliders (6) until flush with one side. Install the pin through the hole in the piston rod (2A) and press the remaining slider into the pin.
2. With the inlet end of the housing upward, press the brass bushing (20), with the shoulder trailing, into the housing.
3. Clamp the housing in copper-covered or leather-covered vise jaws with the inlet end downward.
4. Insert the piston rod (2A), threaded end leading, into the small central opening in the housing. The notch in the trailing end of the rod should be towards the retaining pin hub.
5. Reclamp the housing in the vise with the inlet end upwards.
6. Insert the piston cap (2B), hex end trailing, into the bore of the housing and use a socket to thread and tighten the piston cap onto the piston rod.
7. Thread the end cap (7), O-ring leading, into the bore of the housing and tighten.
8. Wrap the threads of the whip hoses (26) with Teflon tape.
9. Install the male coupler hose into the end cap port and the female coupler hose into the housing port

ASSEMBLY OF TX-2, TX-4, AND TX-8 CYLINDER ASSEMBLIES

1. Clamp the housing (1) in copper-covered or leather-covered vise jaws with the inlet end downward.
2. Apply a non-permanent thread-locking compound to the threads of the cylinder gland (20). Use the gland removal tool (41) to thread the bushing into the small central opening in the housing and tighten until flush with the housing (1). **Note: TX-2 does not have a cylinder gland.**
3. Flip the housing (1) in the vise and install the seal insertion tool (40). **Note:** Lubricating the inside of the insertion tool and the sides of the piston rod assembly and end cap will ease installation.
4. Insert the piston (2) into the seal insertion tool (41), notched end leading and toward the link pin hub, and tap into housing approximately 1”.
5. Insert the end cap (7), swivel inlet toward the link pin hub, into the seal insertion tool (40), and tap in until the piston (2) bottoms out against the housing (1).
6. Install retaining rings (8), tapered edge leading into the grooves in the housing.
7. Flip the housing in the vise and drive the piston (2) into the housing with a brass tap until the end cap (7) seats in the retaining rings (8).
8. Install the end cover (10), applying a non-permanent thread-locking compound to the end cover screw (11) threads.
9. Remove the housing from the vice and place on a soft block with the engraved side up.
10. Install sliders (6), one on each side of piston (2). **For TX-8 models:** Install sliders with the cutout towards the piston. Align the holes in the sliders with the holes in the piston and the housing.
11. Install slider pin (14) until flush with top slider.
12. Apply moly grease to the face of the sliders and the notch in the piston.
13. Wrap the threads of the swivel assemblies (27) with Teflon tape.
14. Install the male coupler swivel into the end cap port and the female coupler swivel into the housing.

MAINTENANCE SECTION

NOTICE

Inspect all parts prior to assembly. Replace any worn or damaged parts.

ASSEMBLY OF TX-16, TX-32 AND TX-45 CYLINDER ASSEMBLIES

1. Press the slider pin (14) into one of the sliders (6) until flush with one side. Install the pin through the hole in the piston rod (2A) and press the remaining slider into the pin.
2. Clamp the housing in copper-covered or leather-covered vise jaws with the inlet end downward.
3. Apply a non-permanent thread-locking compound to the threads of the cylinder gland (20). Use the gland removal tool (41) to thread the gland into the small central opening in the housing and tighten until flush with the housing (1).
4. Insert the piston rod (2A), threaded end leading, into the small cylinder gland in the housing. The notch in the trailing end of the rod should be towards the retaining pin lug.
5. Reclamp the housing so that the inlet end is upwards.
6. Insert the piston cap (2B), hex end trailing, into the bore of the housing and use a socket to thread and tighten the piston cap onto the piston rod.
7. Thread the end cap (7), O-ring leading, into the bore of the housing and tighten with a socket.
8. Wrap the threads of the swivel assemblies (27) with Teflon tape.
9. Install the male coupler swivel into the end cap port and the female coupler into the housing port.

ASSEMBLY OF THE RATCHET LINK

1. If the side plate sleeves (12) were removed, press new sleeves, shoulder end trailing, into the right and left side plates (1 & 2) from the inner face of the side plates. Make certain the sleeves are square with the side plate faces and that the shoulder of the sleeves enters the recesses in the side plates and are pressed flush with the faces.
2. **For Series TX-2, TX-4, and TX-8 models:** Position the upper spacer (8) against the inside face of the right side plate. Apply a non-permanent thread-locking compound to the threads of the two upper spacer screws (15) and secure the spacer with the screws through the side plate. **For Series TX-16, TX-32, TX-45 models:** Press the spacer roll pin (19) into the right side plate with one end of the pin flush with the external face of the side plate. Insert the tab of the upper spacer (8) into the slot in the middle spacer (9). After aligning the holes in both pieces, install them on the spacer roll pin (19). When they are correctly positioned, apply a non-permanent thread-locking compound to the threads of the two upper spacer screws (15) and secure the spacers with the screws through the side plate.
3. Insert the two lower spacer pins (11) into the holes in the lower edge of the right side plate. Apply a non-permanent thread-locking compound to the threads of the lower spacer screws (16) and secure the pins with the screws through the side plate. **Note: The TX-1 ratchet links do not have Upper Spacers and Lower Spacers.**
4. Place the lower spacer (10) over the pins against the side plate. Make certain it is correctly oriented so that no part of the spacer extends beyond the edge of the side plate. **Note: The TX-1 ratchet links do not have Upper Spacers and Lower Spacers.**
5. Insert the drive pin (4) into the small cross-hole and slot in the drive plate (3). Invert the plate causing the ends of the pin to enter the slot and move the pin to the narrow end.
6. Position the drive pin spring (5) in the drive plate slot with the two non-connected ends between the drive pin and the large hole in the slot. Position the closed end of the spring on the opposite side of the pin and then apply pressure on the spring to align the hole through it with the hole in the drive plate for the drive pin spring roll pin (18). Insert the spring roll pin into the drive plate, through the spring and into the far wall of the drive plate.

MAINTENANCE SECTION

NOTICE

In the following step, an excessive amount of grease will prevent proper tooth engagement between the ratchet and the drive segment, causing the tool to malfunction.

7. Wipe a thin film of Marine Moly Grease onto the inner face of the large opening in the drive plate.
8. Position the ratchet (6) in the central opening of the drive plate.
9. Insert the drive segment (7) into the opening adjacent to the ratchet. **Make certain the teeth of the ratchet correctly engage the teeth of the drive segment.** Reverse the ratchet if they do not properly engage.
10. Slide the drive segment sideways to expose the spring hole. Install the segment spring (14) into the hole. While compressing the spring, slide the drive segment inward until the drive plate captures the segment spring.
11. Apply a light coat of Marine Moly Grease to both sides of the drive plate and drive segment as well as the inner races of both side plate sleeves (12).
12. While keeping the assembly together, insert the hub of the ratchet into the side plate sleeve of the assembled side plate.
13. Place the left side plate sleeve on the hub of the ratchet and align the screw holes for the spacers.
14. After applying a non-permanent thread-locking compound to the threads and using hex wrenches, install the two remaining lower spacer screws.

ASSEMBLY OF THE TOOL

1. With the cylinder assembly in one hand and the ratchet link in the other, hook the notch on the shaft of the piston rod (2A) onto the drive pin (4) and bring the two assemblies together.
2. Insert the link pin (9) into the hole in the side plate (1 or 2) until the link pin snaps into the link retaining spring (21).

TROUBLESHOOTING GUIDE

Trouble	Probable Cause	Solution
Piston will not advance or retract	Couplers are not securely attached to the tool or pump	Check the coupler connections and make certain that they are connected.
	Coupler is defective	Replace any defective coupler.
	Defective remote control switch	Replace the switch and/or control pendant.
	Dirt in the direction-control valve of the pump unit	Disassemble the pump and clean the direction-control valve.
Piston will not retract	Hose connections reversed	Make certain the advance on the pump is connected to the advance on the tool and retract on the pump is connected to the retract on the tool.
	Retract hose not connected	Connect the retract hose securely.
	Retract pin and/or spring broken	Replace the broken pin and/or spring.
Cylinder will not build up pressure	Piston seal and/or end plug seal leaking	Replace any defective o-rings.
	Retaining screws sheared	Replace any broken screws.
	Coupler is defective	Replace any defective coupler.
Ratchet will not turn	Grease or dirt build up in the teeth of the ratchet link and drive segment	Disassemble the ratchet and clean the grease or dirt out of the teeth.
	Worn or broken teeth on ratchet and/or drive segment	Replace any worn or damaged parts.
Tool tightens immediately when turned on	Hose connections are reversed	Depress the advance button to release the tool; shut the pump off in the advance position and reverse the hose connection.
Pump will not build up pressure	Defective relief valve	Inspect, adjust or replace the relief valve.
	Air supply too low or air hose too small	Make certain the air supply and hose size comply with the pump manual recommendations.
	Electric power source is too low	Make certain the amperage, voltage and any extension cord size comply with the pump manual requirements.
	Defective gauge	Replace the gauge.
	Low oil level	Check and fill the pump reservoir.
	Clogged filter	Inspect, clean and/or replace the pump filter.
Pressure reading erratic	Defective gauge	Replace the gauge.

