

HYDRAULIC PULLERS - PACKAGE MODELS



■ One complete set with two kinds of puller for user's convenience.



FEATURES

- Four stages of foldable & removable handle saves the handle force during operation.
- 360° Rotary Socket.
- Self-contained hydraulic pump and puller body with integral safety valve.
- Spring loaded live centering nut for easy job (removable).
- 2 jaws puller cross head with manganous-phoosphate plated for rust proof and durability.
- Package including puller body, jaw assembly, cross bearing, extension bar and blow molded case for paractical and safe works.

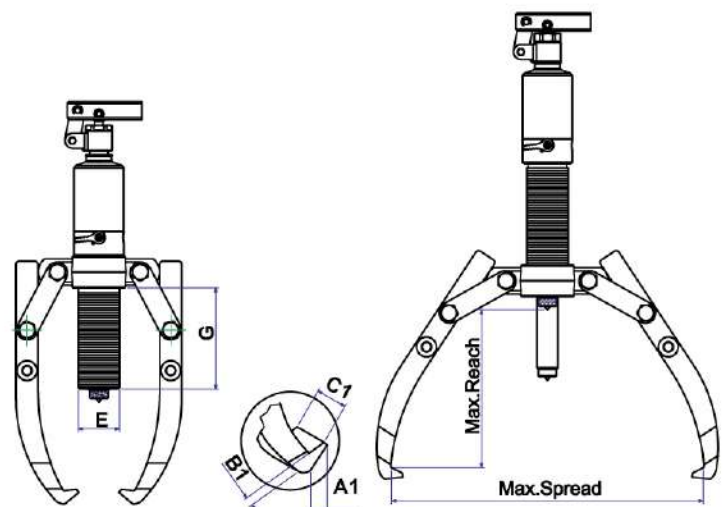
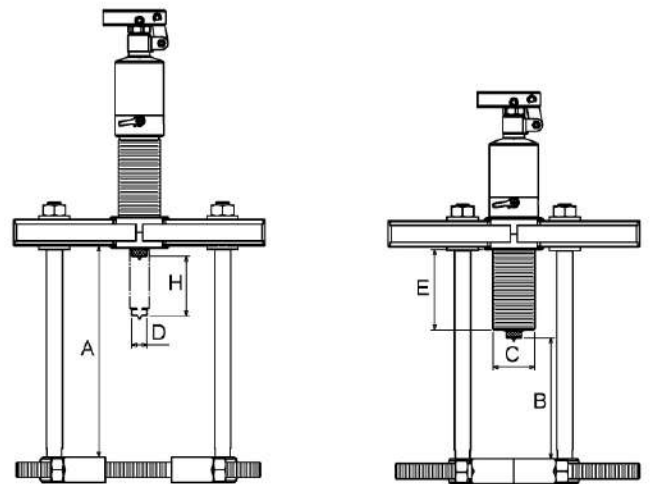

SPECIFICATIONS

Capacity	Model No.	Reach (Max. mm)	Reach (Min. mm)	Stroke (mm)	Pump Tip (mm)			Jaw Tip (mm)			Weight (kg)
		A	B		H	C	D	E	A1	B1	
4 Ton	PM420	211.5	127.5	60	42	22	84	11	6	22	4.5 / 8.5
6 Ton	PM620	243.5	153.5	70	45	23	90	13	10	22	5.5 / 11.5
8 Ton	PM820	243.5	121.5	85	50	25	122	11	10	25	6.5 / 12.6
12 Ton	PM1220	288	173	85	60	28	115	14	10	29	8.0 / 18.0